



EMS-D10

Installation Guide

This product is not approved for installation in type certificated aircraft

P/N 100430-000, Revision I

For use with firmware version 5.4

August, 2010

Copyright © 2003-2010 by Dynon Avionics, Inc.

Contact Information

Dynon Avionics, Inc.
19825 141st Place NE
Woodinville, WA 98072
Phone: (425) 402-0433 - 7:00 AM – 5:00 PM (Pacific Time) Monday - Friday
Fax: (425) 984-1751

Dynon Avionics offers online sales, extensive support, and continually-updated information on its products via its Internet sites:

- www.dynonavionics.com/support –Dynon Avionics primary web site; including:
- docs.dynonavionics.com – Current and archival documentation.
- downloads.dynonavionics.com – Software downloads.
- support.dynonavionics.com – Support resources.
- store.dynonavionics.com – Dynon’s **secure** online store for purchasing all Dynon products 24 hours a day.
- wiki.dynonavionics.com – Dynon Avionics’ Documentation Wiki provides enhanced, extended, continuously-updated online documentation contributed by Dynon employees and customers.
- forum.dynonavionics.com – Dynon Avionics’ Internet forum where Dynon customers can interact and receive Dynon technical support outside of telephone support hours. A key feature of the forum is that it allows the exchange of diagrams, photos, and other types of files.
- newsletter.dynonavionics.com – Dynon’s email newsletter.
- blog.dynonavionics.com – Dynon’s blog where you can find new and interesting Dynon-related content.

Copyright

© 2003-2010 Dynon Avionics, Inc. All rights reserved. No part of this manual may be reproduced, copied, transmitted, disseminated or stored in any storage medium, for any purpose without the express written permission of Dynon Avionics. Dynon Avionics hereby grants permission to download a single copy of this manual and of any revision to this manual onto a hard drive or other electronic storage medium to be viewed for personal use, provided that such electronic or printed copy of this manual or revision must contain the complete text of this copyright notice and provided further that any unauthorized commercial distribution of this manual or any revision hereto is strictly prohibited.

Information in this document is subject to change without notice. Dynon Avionics reserves the right to change or improve its products and to make changes in the content without obligation to notify any person or organization of such changes. Visit the Dynon Avionics website (www.dynonavionics.com) for current updates and supplemental information concerning the use and operation of this and other Dynon Avionics products.

Limited Warranty

Dynon Avionics warrants this product to be free from defects in materials and workmanship for three years from date of shipment. Dynon Avionics will, at its sole option, repair or replace any components that fail in normal use. Such repairs or replacement will be made at no charge to the customer for parts or labor. The customer is, however, responsible for any transportation cost. This warranty does not cover failures due to abuse, misuse, accident, improper installation or unauthorized alteration or repairs.

THE WARRANTIES AND REMEDIES CONTAINED HEREIN ARE EXCLUSIVE, AND IN LIEU OF ALL OTHER WARRANTIES EXPRESSED OR IMPLIED, INCLUDING ANY LIABILITY ARISING UNDER WARRANTY OF MERCHANTABILITY OR FITNESS FOR A PARTICULAR PURPOSE, STATUTORY OR OTHERWISE. THIS WARRANTY GIVES YOU SPECIFIC LEGAL RIGHTS, WHICH MAY VARY FROM STATE TO STATE.

IN NO EVENT SHALL DYNON AVIONICS BE LIABLE FOR ANY INCIDENTAL, SPECIAL, INDIRECT OR CONSEQUENTIAL DAMAGES, WHETHER RESULTING FROM THE USE, MISUSE OR INABILITY TO USE THIS PRODUCT OR FROM DEFECTS IN THE PRODUCT. SOME STATES DO NOT ALLOW THE EXCLUSION OF INCIDENTAL OR CONSEQUENTIAL DAMAGES, SO THE ABOVE LIMITATIONS MAY NOT APPLY TO YOU.

Dynon Avionics retains the exclusive right to repair or replace the instrument or firmware or offer a full refund of the purchase price at its sole discretion. SUCH REMEDY SHALL BE YOUR SOLE AND EXCLUSIVE REMEDY FOR ANY BREACH OF WARRANTY.

These instruments are not intended for use in type certificated aircraft at this time. Dynon Avionics makes no claim as to the suitability of its products in connection with FAR 91.205.

Dynon Avionics’ products incorporate a variety of precise, calibrated electronics. Except for replacing the optional internal backup battery in EFIS-based products per the installation guide, our products do not contain any field/user-serviceable parts. Units that have been found to have been taken apart may not be eligible for repair under warranty. Additionally, once a Dynon Avionics unit is opened up, it will require calibration and verification at our Woodinville, WA offices before it can be considered airworthy.

Table of Contents

Contact Information.....	iii
Copyright.....	iii
Limited Warranty.....	iii
1. Introduction	1-1
OEM Installations.....	1-1
Warning.....	1-1
About this Guide.....	1-2
Menu Descriptions.....	1-2
2. Wiring Overview	2-1
Recommended Wiring Practices.....	2-1
Power Requirements.....	2-1
Grounding.....	2-2
+5V Excitation.....	2-3
Thermocouple Harness Preparation.....	2-3
Harness Mating.....	2-3
37-Pin Female EMS Harness.....	2-4
25-Pin Male EMS Harness.....	2-6
3. Transducer Installation	3-1
Tools and Equipment Required.....	3-1
Exhaust Gas Temperature (EGT) Probes.....	3-2
Cylinder Head Temperature (CHT) Probes.....	3-3
Tachometer.....	3-4
Manifold Pressure Sensor.....	3-5
Oil Pressure Sensor.....	3-6
Oil Temperature Sensor.....	3-7
Fuel Pressure Sensor.....	3-7
Fuel Flow Sensor.....	3-9
Fuel Level Sensor.....	3-11
Ammeter Shunt.....	3-12
General Purpose Inputs.....	3-13
Contacts.....	3-18
General Purpose Thermocouple.....	3-18
4. Instrument Installation	4-1
Power Bus Wiring.....	4-1
Serial Communication Cables.....	4-1
SL30 and/or GPS connection.....	4-2
External EMS Warning Light.....	4-5
Audio Alert Outputs.....	4-5
Dynon Smart Avionics Bus (DSAB) Wiring.....	4-7
Panel Location and Mounting.....	4-8
5. EMS Configuration	5-1
Full-Page Setup Menu Overview.....	5-1
Alarm and Color Threshold Configuration.....	5-2
Global Parameters Setup.....	5-3
Engine Type Configuration.....	5-4
Fuel Level Calibration.....	5-5
Trim Calibration.....	5-6
Flaps Calibration.....	5-7



Tachometer	5-8
Manifold Pressure	5-8
Oil Pressure	5-9
Oil Temperature	5-9
Exhaust Gas Temperature (EGT)	5-10
Cylinder Head Temperature (CHT)	5-11
Fuel Level	5-13
Fuel Pressure	5-13
Fuel Flow	5-13
Fuel Flow	5-14
Voltage	5-15
Current	5-15
General Purpose Inputs	5-16
Contacts	5-19
General Purpose Thermocouple	5-20
6. DSAB Configuration	6-1
Network Concepts	6-1
Example Networks	6-2
Initial Setup	6-4
Network Status	6-4
7. Appendix	7-1
Appendix A: Capacitance-to-Voltage Converter Installation	7-1
Appendix B: Troubleshooting	7-2
Appendix C: Weights	7-3
Appendix D: EMS-D10 Specifications	7-4

1. INTRODUCTION

This manual provides information about the physical and electrical installation of the EMS-D10 and connected sensors. Additionally, this guide deals with setting up the installation-dependant firmware options. Because you may not have purchased all the components, you need only read through the relevant sections of this guide. Information about the *operation* of this instrument can be found in the EMS-D10 Pilot's User Guide.

When properly configured, the EMS-D10 gives an accurate and easy-to-understand display of engine data. To ensure accuracy in its readings, it is very important that you install the instrument correctly and perform the specified setup steps. This installation guide will help you through that process.

OEM Installations

If your EMS-D10 is installed by an OEM distributor, you may find that you are unable to access some menus and settings. Some Dynon distributors customize various areas of the EMS-D10 firmware to maintain a consistent pilot experience and minimize integration issues across a large number of installations. Currently, OEMs can customize access levels to the following settings on Dynon systems: EMS GLOBAL setup menu, EMS SENSOR setup menu, fuel calibration, trim calibration, flaps calibration, GPS/NAV setup menu, screen configurations, data logging, and checklists/data panels. OEM distributors have the option of customizing some or all of these areas. Please contact your aircraft's manufacturer if you have any questions about how your unit has been customized.

Warning

Dynon Avionics' products incorporate a variety of precise, calibrated electronics. Except for replacing the optional internal backup battery in EFIS-based products per the installation guide, our products do not contain any field/user-serviceable parts. Units that have been found to have been taken apart may not be eligible for repair under warranty. Additionally, once a Dynon Avionics unit is opened up, it will require calibration and verification at our Woodinville, WA offices before it can be considered airworthy.



About this Guide

In the electronic (.PDF) version of this manual, page and section references in the Table of Contents and elsewhere act as hyperlinks taking you to the relevant location in the manual. The latest version of this manual is available on the Dynon Avionics website at docs.dynonavionics.com.

The following icons are used in this guide:

- HS34** Any text following this icon describes functionality available only with the HS34 HSI Expansion Module connected to your system.
- AP74** Any text following this icon describes functionality available only with the AP74 Autopilot Interface Module connected to your system.
- DSAB** Any text following this icon describes functionality that is possible when multiple Dynon Avionics products are networked together via the Dynon Smart Avionics Bus (DSAB).
-  Any text following this icon refers to a setting or situation which merits particularly close attention.

Menu Descriptions

Throughout this guide, the “>” character is used to indicate entering a deeper level of the menu system. For example, “EFIS > SETUP > VRSION” indicates entering the EFIS menu, pressing MORE, then pressing SETUP, and then pressing VRSION to enter the firmware version menu. Note that the MORE button is not shown in the sequence, since pressing MORE reveals more options in the same level of the menu system.

2. WIRING OVERVIEW

Please follow these instructions explicitly as improper wiring can result in permanent damage to your instrument and/or the accompanying sensors.

All electrical power and data lines interface with the EMS-D10 via the male 37-pin D-Sub connector on the back of the unit. EGT (exhaust gas temperature) and CHT (cylinder head temperature) thermocouple inputs enter the unit via the female 25-pin D-Sub connector. You should ensure that all electrical connections are tested and properly working before completing the final physical assembly.

Recommended Wiring Practices

⚠ For all electrical connections, use correct wiring techniques, taking care to properly insulate any exposed wire. A short circuit between any of the wires may cause damage to the EMS-D10 and/or your aircraft. Make all connections to your harness before plugging it into any of the components of the system. Do not make connections while power is applied at any point in the system.

Dynon Avionics sells wiring harnesses for all connections to the EMS-D10. The harnesses are made up of 22 AWG wire and – with the exception of the thermocouple harnesses – meet Mil Standard MIL-W-22759/16 (Tefzel insulation). If you have opted not to purchase these harnesses, please refer to the provided wiring diagrams for construction information. We recommend that all wire you use also meets Mil Standard MIL-W-22759/16; all wire supplied by Dynon Avionics (with the exception of thermocouple wire, which uses FEP insulation) meets this specification.

When using *any* pre-manufactured harness, verify that each pin has continuity with the expected wire on the wiring diagram. This test can be easily done with a multimeter. When verifying harnesses, use the wiring charts and diagrams in this guide as your ultimate authority on pin function (for any harness) and wire color (for harnesses purchased from Dynon Avionics).

Route all wiring through the engine compartment such that there are no spots where it could chafe or break. Use appropriate strain relief at all junctions between wires and connectors. We recommend that you secure all wires at regular intervals along wiring runs to accommodate vibration effects.

In the sections below, each connection that needs to be made has an associated legend, as shown at right. This legend refers to pin numbers and colors *on the EMS female 37-pin harness only*. All connections on the EMS male 25-pin harness route to thermocouples and are color-coded to correspond to the thermocouple coloring.

Pin	Color	Function
#	Color	function

Power Requirements

22 AWG wire is normally sufficient for the power supply and ground lines, but we recommend that you consult a wire sizing chart and determine the size required for the wire routing in your



particular aircraft. Ensure that the power lines include a circuit breaker or an appropriately sized fuse for the wire you select.

The EMS-D10 system-wide power requirement is **8 watts** typical and **10 watts** maximum. On a 12-volt system, this translates to about 1 amp of maximum current draw. On a 24-volt system, this translates to about 0.5 amps maximum current draw. Normally, a 2-amp circuit breaker or fuse is sufficient.

Grounding

Many of the engine sensors require a connection to a shared electrical ground with the EMS-D10. There are many places on an aircraft where you could connect these sensors. However, the ideal location to ground these sensors is near the EMS-D10 to minimize voltage differences between the sensor and instrument grounds.

Pin	Color	Function
5	Black	Ground
16	Black	Ground
17	Black	Ground

Some sensors (e.g., oil pressure and oil temperature) connect to ground via their cases' contact with the engine or aircraft body. There must be a solid connection between this "case ground" and the EMS-D10 ground. The oil temperature sensor is very susceptible to voltage differences between the engine case and the negative terminal of the battery. Ensure that solid, thick electrical connections exist between the engine and battery ground. Other sensors (e.g., fuel pressure) do not have a grounded case and have two leads instead. One lead must be connected to ground, the other to the sensing input of the EMS-D10. The EMS-D10 has 3 pins on the 37-pin harness which may be used for connecting such sensors to ground. More than one sensor's ground may be connected to any of these three grounds using a splice.

The case of the EMS-D10 is connected to its supply ground. If your panel is connected to aircraft ground, the connection between the instrument's case and the panel dramatically helps minimize voltage differences between the instrument and sensor grounds. If your panel is not metal, or is otherwise isolated from engine ground, connect a 14 AWG or larger wire to the instrument case. The most convenient place to do this is at the back of the mounting tray. Additionally, connect any unused EMS ground leads to a convenient ground. Keep all ground leads as short as possible.

Because of the current drawn by the EMS-D10, even very small resistances between battery ground and instrument ground can cause voltage differences which adversely affect engine sensor readings. An easy way to test the quality of the instrument's ground is to measure voltage between the ground pin at the EMS-D10 and the ground lead at your aircraft's battery. With the EMS-D10 powered on, connect one lead of your voltmeter to a free ground lead coming from the EMS-D10. Connect the other lead of your voltmeter to the ground terminal of your battery. The voltage between these two points should measure very close to 0 mV (within 5 mV). If it does not, you must improve the ground connection between the ground of your battery and that of your avionics bus.



+5V Excitation

Some of the sensors require either a direct connection, or connection via a resistor, to the +5V excitation circuit. We recommend that you allow for more than one splice into this line.

Pin	Color	Function
18	White/red	+5V excitation

Thermocouple Harness Preparation

Refer to the 25-Pin Male EMS Harness section on page 2-6 during this procedure. Strip 1” of brown outer insulation off each thermocouple wire pair on the supplied 25-pin thermocouple harness. Strip ¼” of insulation from each of the thermocouple wires inside. Crimp the supplied male Fastons onto each wire on the thermocouple harness. These will later be inserted into the female Fastons on each thermocouple.

Do not connect the Fastons on the harness with those on the thermocouples until you have routed the wires and mounted the thermocouples at the desired location.

The thermocouple wires can be cut to a desired length if your application requires. If you need to extend the length of the thermocouple, you *must* use the correct type (J or K) thermocouple wire to accomplish this. It is acceptable to use non-thermocouple fasteners to join two pieces of thermocouple pair wire, provided the junction does not extend very far or have large temperature differences across it. Please contact Dynon Avionics to order extension wire.

Harness Mating

The following diagram shows the 2 electrical connectors on the back of the EMS-D10. The main EMS harness (for all connections except EGT & CHT thermocouples) should terminate in a 37-pin female D-sub connector. The EGT/CHT thermocouple harness should terminate in a 25-pin male D-sub connector. The following pages provide wiring diagrams and details for each of these harnesses.

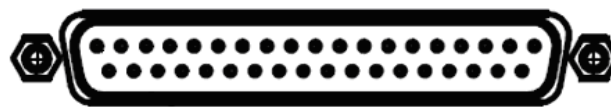

EMS 37-pin D-sub

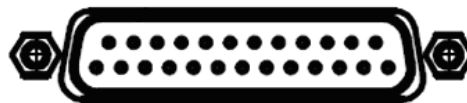

EMS 25-pin D-sub
CHTs, EGTs



37-Pin Female EMS Harness

Below is the wiring diagram of the EMS 37-pin female harness. Refer to the following page for detailed pin out descriptions.

D-37 Female
Pin Insertion View

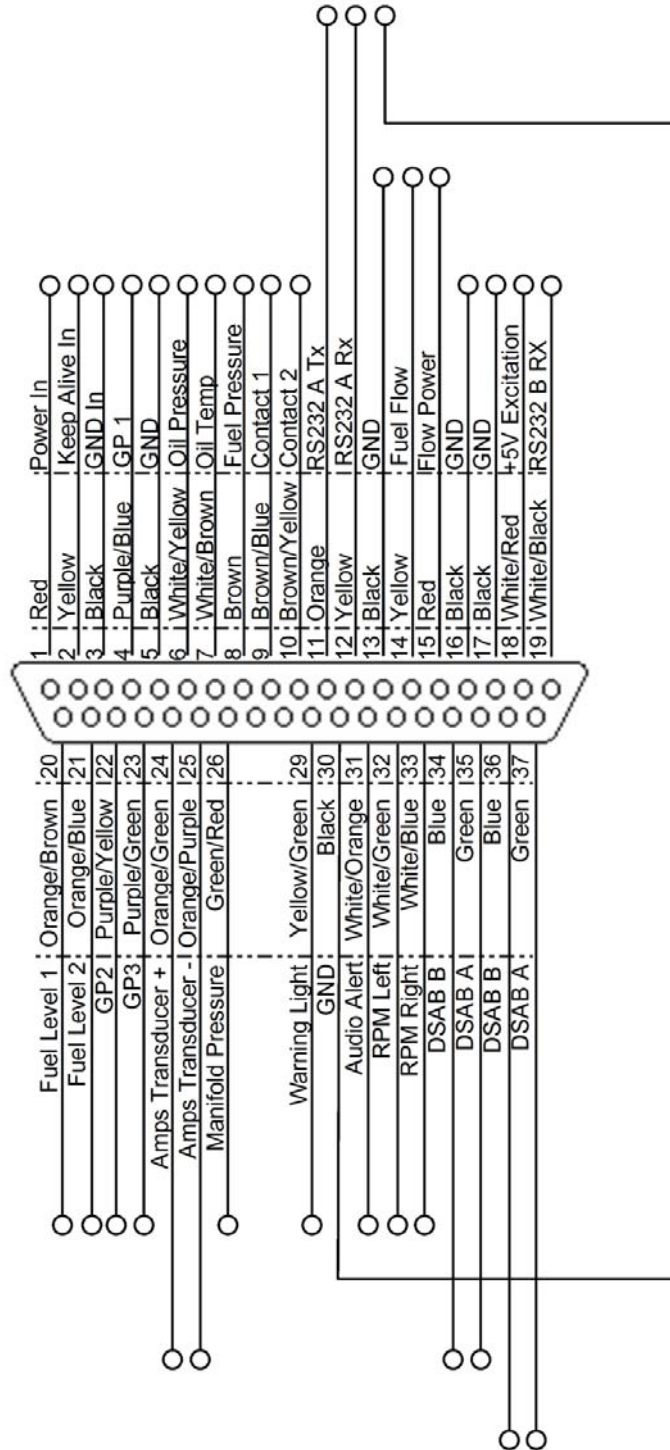



The pin assignments for the female 37-pin harness are repeated below. *Note that the pin numbers are labeled on the face of both the female and male connector.* Each connection on the harness supplied by Dynon is color-coded. These colors are listed in the following chart.

DB37 harness Pin#	Dynon Harness Wire color	Function	Details
1	Red	Master Power (10-30V)	Page 4-1
2	Yellow	Keep Alive (10-30V, low current)	Page 4-1
3	Black	Master Ground	Page 2-2
4	Purple/blue	GP 1 (general purpose resistive)	Page 3-13
5	Black	Ground	Page 2-2
6	White/yellow	Oil pressure	Page 3-6
7	White/brown	Oil temperature	Page 3-6
8	Brown	Fuel pressure	Page 3-7
9	Brown/blue	Contact 1	Page 3-18
10	Brown/yellow	Contact 2	Page 3-18
11	Orange	EMS-D10 Transmit / PC Serial Receive (RS-232)	Page 4-2
12	Yellow	EMS-D10 Receive / PC Serial Transmit (RS-232)	Page 4-2
13	Black	Ground (Fuel Flow)	Page 3-9
14	Yellow	Fuel flow input	Page 3-9
15	Red	Fuel flow power (12V)	Page 3-9
16	Black	Ground	Page 2-2
17	Black	Ground	Page 2-2
18	White/red	5V excitation circuit	Page 2-2
19	White/black	Auxiliary Serial Receive (RS-232)	Page 4-2
20	Orange/brown	Fuel level 1	Page 3-11
21	Orange/blue	Fuel level 2	Page 3-11
22	Purple/yellow	GP 2 (General Purpose Resistive)	Page 3-13
23	Purple/green	GP 3 (General Purpose Resistive)	Page 3-13
24	Orange/green	Amps High	Page 3-12
25	Orange/purple	Amps Low	Page 3-12
26	Green/red	Manifold pressure	Page 3-5
27	Not supplied	General purpose thermocouple (J or K-type)	Page 3-18
28	Not supplied	General purpose thermocouple (J or K-type)	Page 3-18
29	Yellow/green	External warning light	Page 4-2
30	Black	PC Serial ground	Page 4-2
31	White/orange	Intercom audio alert	Page 4-2
32	White/green	RPM left	Page 3-4
33	White/blue	RPM right	Page 3-4
34	Blue	DSAB B	Page 4-7
35	Green	DSAB A	Page 4-7
36	Blue	DSAB B	Page 4-7
37	Green	DSAB A	Page 4-7



25-Pin Male EMS Harness

Below is the EMS 25-pin harness wiring diagram. The 4-cylinder harness only has EGTs 1 through 4 and CHTs 1 through 4 wired. The Rotax harness only has EGTs 1 and 2 wired, as the EMS measures the Rotax-supplied resistive CHTs through its GP inputs. On the supplied harness, each pair of wires is encased in brown insulation and labeled with corresponding cylinder number. Inside the outer insulations, each wire in the pair has the color listed on the diagram below. If you are making your own harness, utilize J & K type thermocouple wire as indicated in the diagram.

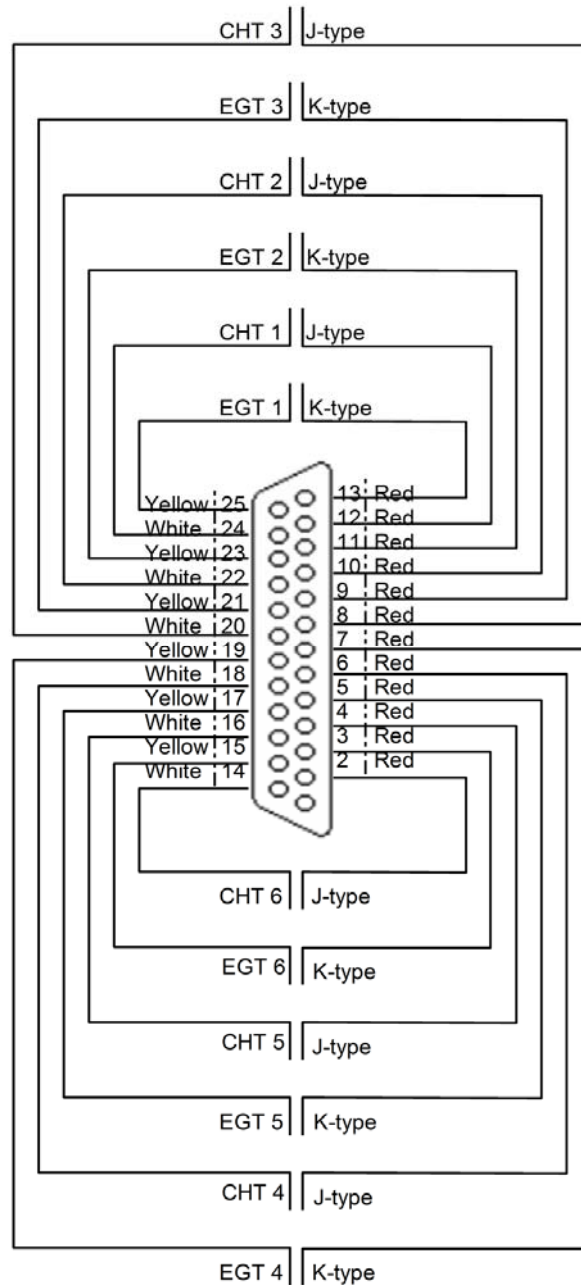

3. TRANSDUCER INSTALLATION

This section explains the steps required to install and connect all transducers supplied by Dynon Avionics. Additionally, connection instructions are given for some transducers that Dynon Avionics does not sell, like the tachometer, fuel level, flaps, trim, and contacts.

Tools and Equipment Required

The following list contains commonly used tools and equipment; however some of the tools or equipment listed below may not apply to your installation.

- Wire strippers
- 22 AWG wire (if harness not purchased or extending harness beyond 6 feet)
- D-sub pin crimper
- Faston/ring terminal crimp tool
 - Available from www.bandcspecialty.com – (316) 283-8000 – part number RCT-1
- Weather Pack crimp tool (common slip joint pliers will also work)
 - Available from www.whiteproducts.com/tools.shtml
- #2 Phillips screwdriver
- Flathead screwdriver
- ¼” ID tubes, any necessary adapters, and clamps for routing manifold pressure to the sensor.
- Drill and 1/8” bit



Exhaust Gas Temperature (EGT) Probes

Correct placement of EGT probes on the exhaust manifold is critical to obtaining accurate readings. Placement differs between engine types, and even specific models. *Consult your specific engine's manual for proper EGT locations.*

ROTAX ENGINES

For Rotax 912 engines, only two of the four cylinders are typically monitored for EGT. Unlike the CHT probes which are mounted on diagonal cylinders, the EGT probes should be mounted on the two rear cylinders' exhaust manifolds. It is critical that the EGT probes be mounted to parallel cylinders' exhaust manifolds for proper temperature comparison.

ALL ENGINES

Once you have determined the appropriate EGT locations for your engine, drill 1/8" diameter holes at the specified positions in the exhaust manifold. Usually, this spot is 2 to 8 inches from the cylinder. This spot should be on a straight portion of the exhaust manifold, as this provides a better fit for the hose clamps. For best results, mount all probes the same distance from each cylinder.

1. Make sure the hole is placed to ensure that the probe does not interfere with the cowl or spark plug. Also, when making holes, keep in mind that the probe could inhibit the ability to perform routine maintenance if placed incorrectly.
2. Place probe in exhaust manifold, and secure it by tightening the clamp with a flathead screwdriver. Make sure the clamp is tight and provides a secure fit, but do not over-tighten such that visible stress is put on the pipe.

Now, plug each thermocouple wire into its corresponding wire on the thermocouple harness. Ensure that you match the wire color pairs on the harness to those on the thermocouple. All thermocouple harnesses supplied by Dynon have each function (e.g., CHT1, EGT1) labeled on each thermocouple pair.

- ❗ A loose probe could allow exhaust to leak. This can lead to carbon monoxide poisoning in the cabin and/or a potential fire. Have a knowledgeable mechanic inspect the installation.
- ❗ The probe can come lose during flight, and could potentially come in contact with rotating engine parts or the propeller. We suggest a safety wire to keep the probe in place.



Cylinder Head Temperature (CHT) Probes

Dynon Avionics sells and supports a variety of CHT probes. All thermocouple harnesses supplied by Dynon have each function (e.g., CHT1, EGT1) labeled on each thermocouple pair.

LYCOMING/CONTINENTAL

Dynon Avionics sells bayonet style CHT probes (used in Lycoming and Continental engines). With each probe we sell, a bayonet adapter is included. Your specific engine manual should describe where to mount these bayonet adapters, but normally, there is a threaded hole (CHT well) near the bottom of the cylinder close to the lower spark plug. Screw the bayonet adapter into this hole. Screw the locking collar up or down the spring surrounding the probe such that the tip of the probe is pressed against the bottom of the CHT well when the collar is attached to the adapter. Insert the CHT probe into the well and lock the collar to the adapter. Now, plug each thermocouple wire into its corresponding wire on the thermocouple harness. Ensure that you match the wire color pairs on the harness to those on the thermocouples.

ROTAX

Rotax 912 engines use 2 resistive CHT probes that are included with the engine. These probes are preinstalled, but you need to route the connections from them to the EMS-D10. See the Rotax CHT Sensors section on page 3-15 for information on making the physical connection to the sensor.

JABIRU

Jabiru engines require a 12mm ring-terminal CHT probe for each cylinder. First, slide the compression washer off the spark plug. Slide the 12mm ring-terminal probe onto the plug. Now, slide the spark plug compression washer back onto the spark plug. Reinstall the spark plug into the spark plug hole. Please refer to the documentation that came with your engine for more information. Now, plug each thermocouple wire into its corresponding wire on the thermocouple harness. Ensure that you match the wire color pairs on the harness to those on the thermocouples.

Tachometer

Dynon Avionics does not sell a tachometer transducer.

Depending upon existing equipment and engine type, you have a few options for connecting the tachometer inputs on the EMS-D10. See the relevant subsections below for your particular method. You may connect different types of signals to the two different RPM inputs (e.g., p-lead to RPM Left and a 12V transducer to RPM Right). Once you have connected the tachometer inputs according to your engine and transducer type, you must set the appropriate pulses/revolution as described on page 5-8.

Pin	Color	Function
32	White/green	RPM Left
33	White/blue	RPM Right

TACHOMETER TRANSDUCER

If you have a standard tachometer transducer (usually with a 12V output), you may simply connect its output to the **RPM Left** input on the EMS-D10. Ensure that you follow all recommendations given in the manual for your individual tachometer transducer.

P-LEAD PICKOFF (LYCOMING AND CONTINENTAL)

If you do not have a standard tachometer pickoff, you must follow the instructions below. The magneto P-lead has high voltages which can very easily damage the EMS-D10 if not dealt with properly.

Use the two included 30k Ω resistors (color bands: orange, black, brown, red, brown; connect in either direction) to attach left and right P-leads to the RPM Left and RPM Right inputs on the EMS-D10. Connect them as shown in the diagram. It is important to connect each resistor as close as possible to the spot where you tap into the P-lead. This minimizes the length of cable carrying high voltage spikes. 6 cylinder Lycoming engines sometimes need more inline resistance to prevent false readings by the EMS-D10.

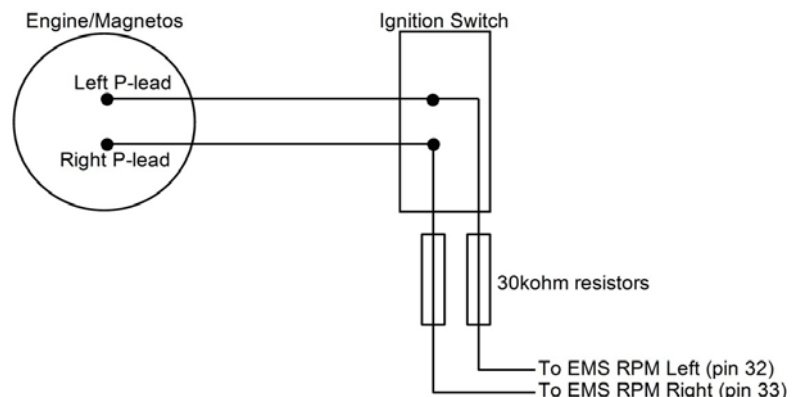

If, after setting the PULS/REV R and L values as described on page 5-8, you see higher than expected RPM or unstable values, you may need to increase the series resistance to as high as 150k Ω .

TRIGGER COIL (ROTAX)

The Rotax 912 engines have a 5th trigger coil for the purposes of electrically monitoring rev counts. This trigger coil outputs to a two-wire harness. Connect either of the two wires to ground; connect the other to one of the included 30k Ω resistors (color bands: orange, black, brown, red, brown; connect in either direction). Connect the other end of the resistor to the RPM Left input on the EMS-D10.

ALTERNATOR WIRE (JABIRU)

The most common tachometer pickoff location for Jabiru 2200 and 3300 engines is one of the alternator wires. Splice a wire off one of the two white alternator wires, connect it through a 1-amp fuse to the RPM Left input on the EMS-D10.

DIGITAL IGNITION AND OTHER PICKOFFS

The EMS-D10 can read frequency-based RPM signals, provided the peak voltage is at least 10 volts above ground. If the peak voltage exceeds 50 volts, use the included 30kΩ resistors as described in the P-lead Pickoff section above. Like the other methods above, you must know the number of pulses per revolution for your RPM transducer.

Manifold Pressure Sensor

The manifold pressure sensor is an integral assembly consisting of three pins, a rubber seal, and a connector housing. Strip 3/16” insulation off the ends of the three wires listed at right. Slide the three rubber seals onto the three wires and the pins onto the ends of the wires. Crimp the 3 provided pins onto the ends of the wires, ensuring that the long tabs that cradle the rubber seal wrap around the seal (see picture at right for example). For more details on preparing and crimping the Weather Pack pins, see www.whiteproducts.net/faqs.shtml.

Note that you will need access to the +5V excitation circuit for other sensor installations, so make allowances for breaking out the connection to other areas. Route the three wires to the location where you would like to mount the manifold pressure sensor.

Plug the crimped pins into the provided Weatherpack connector. Now, mount the manifold pressure sensor in a secure fashion using the mounting holes on either side of the sensor.

The pressure port on the manifold pressure sensor requires 1/4” inner diameter tubing for a secure fit. You may need to use adapters to convert down to smaller inner diameter tubing for your specific engine. We recommend that you use pipe clamps at every transition point, including at the sensor itself.

If you notice fluctuations on the manifold pressure reading on the EMS-D10, you may need to install a restrictor with a small hole inline between the sensor and the head where the manifold pressure line is split off.

Pin	Weather Pack Pin#	Color	Function
18	C	White/red	+5V excitation
26	B	Green/red	Manifold pressure
17	A	Black	Ground

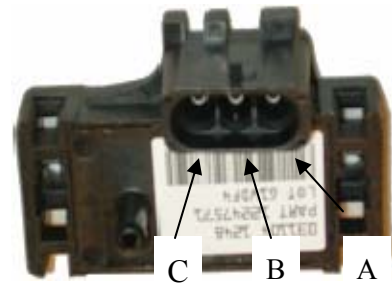

Figure 1 Connection diagram for sensor with all black wires only

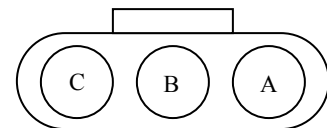

Figure 2: Pin insertion (rear) view of supplied connector.



Figure 3: Detail view of properly crimped pin.



Oil Pressure Sensor

The EMS-D10 supports several oil pressure sensor installations. The Dynon-supplied sensor and the Rotax and Jabiru pre-installed sensors are the most common.

DYNON-SUPPLIED OIL PRESSURE SENSOR

First, mount the oil pressure sensor to a fixed location using an Adel clamp (see picture at lower right) or other secure method. The oil pressure sensor must *not* be installed directly to the engine due to potential vibration problems. Dynon Avionics' sensor is supplied with a 1/8" NPT pipe thread fitting. An adapter might be necessary for some engines. Please see the manual supplied by the engine's manufacturer. You must use appropriate pipe fitting adapters and *ensure that the case of the sender has a connection to ground*. This is critical for functionality.

Crimp a standard #8 ring terminal onto the white/yellow wire from pin 6. Unscrew the stud cap from the threaded stud. Place the ring terminal on the stud and secure the cap down sandwiching the ring terminal.

- ❗ Due to vibration issues, never connect the sensor directly to the engine.
- ❗ If you use Teflon tape or other seal, ensure the sensor casing still maintains a good connection to ground.

JABIRU AND ROTAX OIL PRESSURE

If you are installing on a Jabiru or Rotax engine, your engine comes with a pre-installed oil pressure sensor.

Prior to mid-2008, Rotax provided an oil pressure sensor with 2 tabs for electrical connection. In mid-2008, Rotax switched to a new type of oil pressure sensor (Rotax P/N 956413) with an integrated 2-wire cable. Connect this newer sensor according to the wiring diagram at right. Connect the red wire of the new sensor to EMS DB37 Pin 15 (12V). Connect the white wire of the new sensor to EMS DB37 Pin 6. Then, connect one end of a 200Ω resistor to pin 6, and the other end to ground. The Jabiru and both types of Rotax oil pressure sensors are compatible with the FlightDEK-D180. Select the correct sensor type as described in the Oil Pressure Configuration section on page 5-9.

Pin	Color	Function
6	White/yellow	Oil pressure



1/8-27 NPT
0-150 PSI



Use an Adel clamp similar to the above to secure the pressure sensor

37-pin Connector

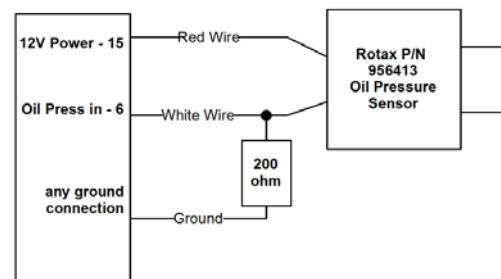

Oil Temperature Sensor

The oil temperature sensor needs to be installed according to the directions of the engine manufacturer. Dynon Avionics sells oil temperature sensors with both 5/8-18 UNF (Dynon P/N 100409-001) and 1/8-27 NPT (Dynon P/N 100409-000) threads. Ensure that you have the right sensor for your engine. Using a crush washer (not provided) between the sensor and the engine case, tighten the sensor according to your engine manufacturer's recommendations.

Route the wire from pin 7 on the 37-pin harness to where the oil temperature sensor is mounted. When routing the wires, make sure that they are secured, so they will not shift position due to vibration. Strip ¼" of insulation off the end of the wire. Crimp a #10 ring terminal onto the end of the wire, ensuring that a good connection is made between the wire and the connector. Unscrew the nut from the stud on the oil temperature sensor. Slip the ring terminal onto the stud and secure the nut over it.

As mentioned in the Grounding section on page 2-2, the oil temperature sensor is very susceptible to voltage differences between the engine case and the negative terminal of the battery. Ensure that solid, thick, and short electrical connections exist between the engine and battery ground.

Pin	Color	Function
7	White/brown	Oil Temperature



1/8-27 NPT



5/8-18 UNF

Fuel Pressure Sensor

First, mount the fuel pressure sensor to a fixed location using an Adel clamp or other secure method. The fuel pressure sensor must *not* be installed directly to the engine due to potential vibration problems. Next, connect the fuel sensor to the engine using appropriate hoses and fittings. Its pressure port has a 1/8-27 NPT pipe thread fitting; you may need adapters to connect to the pressure port on your engine. Locate the correct fuel pressure port for your engine. This port must have a pressure fitting with a restrictor hole in it. This restrictor hole ensures that, in the event of a sensor failure, fuel leakage rate is minimized, allowing time for an emergency landing.

Carbureted engines: Use the 0-30 PSI sensor (Dynon P/N 100411-000). Crimp a standard ¼" female Faston onto one of the ground wires (see the Grounding section on page 2-2) coming from the 37-pin harness. Crimp another ¼" female Faston onto the brown wire from pin 8. Push the two Fastons onto the two terminals on the fuel pressure sensor. Polarity is not important. If you

Pin	Color	Function
8	Brown	Fuel Pressure



1/8-27 NPT
0-30 PSI



1/8-27 NPT
0-80 PSI



are converting from a GRT EIS system, you must disconnect the external resistor pull-up from the fuel pressure output. This will make the sensor output equivalent to the sensor supplied by Dynon Avionics.

Injected engines: Use the 0-80 PSI sensor (Dynon P/N 100411-001). Crimp a standard #8 ring terminal onto the brown wire from pin 8. Unscrew the stud cap from the threaded stud. Place the ring terminal on the stud and secure the cap down sandwiching the ring terminal. If the connection between the sensor and your engine is non-metallic, you must connect the sensor case to ground through other means. The best way to accomplish this is by sandwiching a ground-connected ring terminal between the sensor and the mating fitting.

- ❗ Due to vibration issues, never connect the sensor directly to engine.
- ❗ If you use Teflon tape or other seal, ensure the sensor casing still maintains a good connection to ground.

Fuel Flow Sensor

Dynon Avionics supplies two different fuel flow transducers:

- Floscan 201B (Dynon P/N 100403-001)
- Electronics International FT-60 (Dynon P/N 100403-003)

Pin	Color	Function
13	Black	Ground
14	Yellow (or white)	Fuel flow input
15	Red	Fuel flow power (14V)

GENERAL PLACEMENT RECOMMENDATIONS

When placing either sensor, ensure that the three wire leads are pointed **straight up**. A filter should be placed upstream from the sensor to screen out debris. Placement of the fuel flow sender relative to other items in the fuel system like fuel pumps is left to the builder. The manufacturer of the fuel flow sender does not make strong recommendations on this point. It is not uncommon, though, to place the sender downstream of any auxiliary electric boost pumps but upstream of the engine driven fuel pump. For best measuring performance, the fuel should travel uphill by one to two inches after leaving the fuel flow sender.

- ! Due to vibration issues, never connect the sensor directly to engine.
- ! Do NOT use Teflon tape when screwing in any of the fittings.

FLOSCAN TRANSDUCER INSTALLATION

The FloScan fuel flow transducer has ¼” female NPT threads at both the inlet and outlet. Only use ¼” NPT fittings to match. When installing, do not screw fittings more than two full turns past hand tightened. The torque should not exceed 180 inch-lbs.

Make note of the numbers on the tag attached to the fuel flow sensor. You will need it in the Fuel Flow Configuration section on page 5-14.



EI “RED CUBE” INSTALLATION

The Electronics International “Red Cube” FT-60 flow transducer has ¼” female NPT ports. Do not exceed a torque of 300 inch-lbs when installing fittings into the transducer. The fuel line on the outlet port should not drop down after exiting the transducer. This configuration can trap bubbles in the transducer, causing jumpy readings.

The inlet port, outlet port, and flow direction are marked on the top of the FT-60.

ROTAX PLACEMENT RECOMMENDATIONS

If installing on a Rotax 912, review the following page for recommendations specific to these engines.

912(ULS) Installation

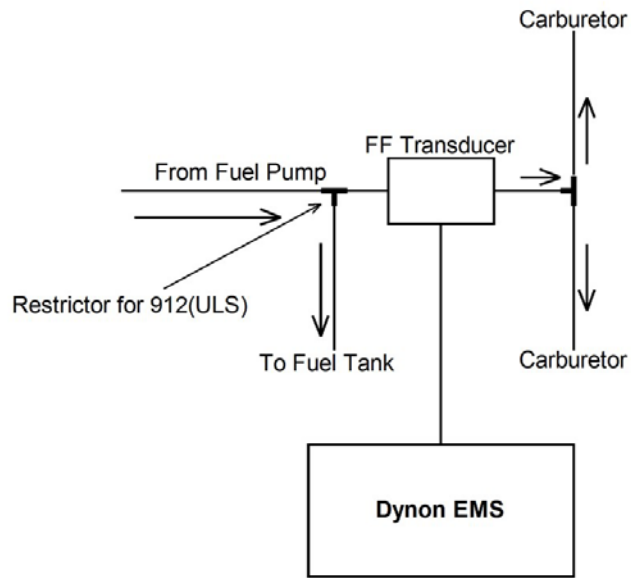

912(ULS) or 914 Installation

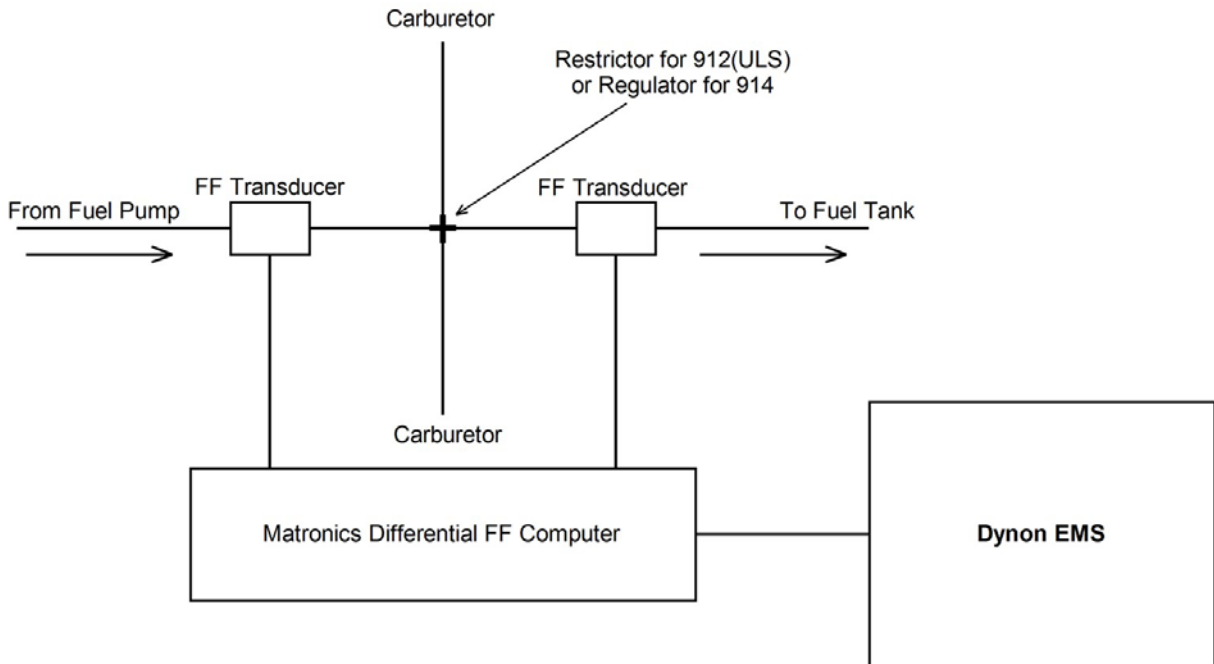



Fuel Level Sensor

Dynon Avionics does not sell fuel level sensors.

The EMS-D10 supports both resistive type sensors as well as capacitive sensors which output a voltage (e.g., Princeton). If you have a capacitive sensor which does not output a voltage on its own, you may be able to use Dynon's Capacitance-to-Voltage Converter. Read the relevant section below for the type that you are installing.

Once you have installed your fuel level sensors, you will need to calibrate each of them, as described in Fuel Level Calibration on page 5-5.

Pin	Color	Function
20	Orange/brown	Fuel level 1 (resist or cap)
21	Orange/blue	Fuel level 2 (resist or cap)
See General Purpose Inputs section		
4	Purple/blue	GP 1
22	Purple/yellow	GP 2
23	Purple/green	GP 3

RESISTIVE FUEL LEVEL SENSOR

You may connect up to four resistive fuel level sensors to the EMS-D10. Simply connect the output of the sensor you would like to be Fuel Level 1 (left tank) to pin 20 and the sensor you would like to be Fuel Level 2 (right tank) to pin 21. You may also connect third and fourth fuel level transducers to the general-purpose inputs of your choice. See the General Purpose Inputs section on page 3-15 for more information.

CAPACITIVE FUEL LEVEL SENSOR

Capacitive fuel level sensors are only supported on the Fuel Level 1 and Fuel Level 2 inputs. Additionally, your capacitive sensor needs to output a variable voltage within the ranges of 0-5Vdc. First, supply the sensor with power according to the manufacturer's instructions. If the sensor manufacturer requires a sensor calibration, perform that calibration first. Connect the sensor's output to pin 20 or 21, depending on whether you want the tank to display as left (Fuel Level 1) or right (Fuel Level 2) tank. Do not connect capacitive fuel level sensors to any of the general-purpose inputs. Be sure to configure the firmware to recognize the capacitive fuel level sensor on the fuel level input(s) you've chosen as described in the Fuel Level Configuration section on page 5-13.

If you are installing Dynon's Capacitance-to-Voltage Converter (most commonly used with the capacitive plates in some RVs), please read its installation guide in the Appendix on page 7-1.

Ammeter Shunt

The ammeter shunt should be mounted so that the metal part of the shunt cannot touch any part of the aircraft. The ammeter shunt can be installed in your electrical system in one of three locations as shown in the (simplified) electrical diagram below.

Pin	Color	Function
24	Orange/green	amps high
25	Orange/purple	amps low

- Position A: Ammeter indicates current flow into or out of your battery. In this position, it will show both positive and negative currents. (-60A to 60A)
- Position B: Ammeter indicates only the positive currents flowing from the alternator to both the battery and aircraft loads. (0A-60A)
- Position C: Ammeter indicates the current flowing only into the aircraft loads. (0A-60A)



Note that the ammeter shunt is not designed for the high current required by the starter and must not be installed in the electrical path between the battery and starter.

- ! Electrically, the shunt should be placed so that it does not receive power when the master switch is off. If it does receive power in this case, it is possible for your aircraft battery to slowly discharge over a few weeks or months.

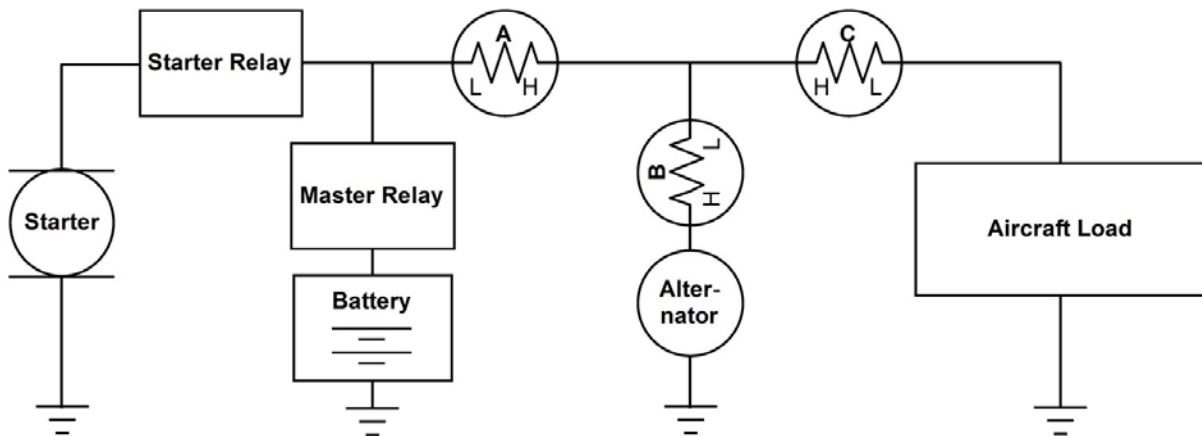

Use two ¼" ring terminals sized appropriately for the high-current wire gauge you will be routing to and from the ammeter shunt. Cut the wire where you would like to install the ammeter shunt. Strip the wire and crimp on the ring terminals. Using a Phillips screwdriver, remove the two large screws (one on either end of the shunt), slip the ring terminals on, and screw them back into the base.

We highly recommend that you fuse both the connections between the shunt and the EMS-D10. There are two methods for accomplishing this. You may simply connect two 1 amp fuses in-line between the shunt and the EMS-D10. Or, you may use butt splices to connect 1" to 2" sections of 26 AWG wire between the shunt and each of the Amps leads connecting to the EMS-D10. These fusible links are a simple and cost-effective way to protect against short-circuits.



Next, crimp the two supplied #8 ring terminals onto the wires using the fusing method chosen above. Connect the other ends of the fuses to the Amps High and Amps Low leads (pins 24 and 25) on the 37 pin harness. Unscrew the two smaller screws on the ammeter shunt. Slide the ring terminals onto them and screw them back into the base. The “Amps High” lead should be located on the side of the shunt which is closest to the battery, or in the case of position B, closest to the alternator.

If you find that the current reading on the EMS-D10 is the opposite polarity of what you want, swap the two signal inputs (Amps High and Amps Low) to obtain the desired result.

! It is extremely important that you secure all loose wires and ensure that exposed terminals cannot touch or short out to other objects in the plane. All metal on the shunt is at the same voltage as – and carries the same risks as – the positive terminal on the battery. Improperly installing the ammeter shunt can result in high current flow, electrical system failure, or fire.

If you are using GRT’s Hall effect amps transducer (P/N CS-01), route its output to pin 24, the Amps High input, on the 37-pin EMS connector.

General Purpose Inputs

Dynon Avionics supports many sensors for which the EMS-D10 does not have dedicated inputs. The instrument has 3 GP (general-purpose) inputs which can be used for a variety of sources.

Pin	Color	Function
4	Purple/blue	GP 1
22	Purple/yellow	GP 2
23	Purple/green	GP 3

OUTSIDE AIR TEMPERATURE SENSOR

Note that this section only applies to the OAT with 2 wires (both colored black/white), for connection to the EMS DB37 connector. If you have the 3-wire OAT and an EFIS-based product, see that product’s Installation Guide for more information on connecting the OAT to that product. If you do not have an EFIS product, you may still use the 3-wire OAT, by ignoring the red wire and connecting the yellow and blue wires (irrespective of polarity) in the same way as the black/white wires described here.

Pin	EMS harness Color	OAT sensor color	Function
Desired GP input #	See chart above	Black/White	GP
Ground pin	Black	Black/White	ground

Mount Location

It is important that the OAT probe be mounted somewhere on the skin of the aircraft where it will not be affected by heat sources (sun, engine, aircraft interior, etc). The ideal location would receive no heat from the aircraft engine or any other source in the aircraft body. While this may be impractical, it is a good idea to mount the probe as far away from heat sources as possible. On the RV series, common locations include the wingtip and under the horizontal stabilizer. Avoid these three locations:

- Engine exhaust paths
- The engine itself
- Where the sensor will have direct sunlight
- Where the backside is exposed to a heated cabin

Mounting Instructions

After the mounting location has been determined, drill a 3/8" hole in the skin at the desired location. Uncoil the cable attached to the OAT probe. Remove the nylon nut from the cable. From outside the skin of the aircraft, insert the cable first and then the threaded end of the OAT probe. From within the skin of the aircraft, gently pull the cable until the threaded end of the OAT probe pokes through the hole. Thread the nylon nut down the cable and up to the threaded end of the OAT probe. Spread some Loctite around the threads of the OAT probe. Twist the nut onto the threads of the OAT probe and tighten.

Wiring Instructions.

Once you have physically mounted the OAT probe, route its attached cable to the EMS-D10. Connect one of the black/white wires to ground, either at a supplied connection on the 37-pin harness or at another convenient location. If using the EFIS 3-wire OAT simply route either the yellow or blue wire to ground.

Connect the other black/white wire on the OAT probe to the desired GP input on the EMS-D10 main harness. Again, if using the EFIS 3-wire OAT simply route either the yellow or blue wire (whichever did not get routed to ground) to the desired GP input. When routing wires for this sensor, try to keep wires away from radios, ignition, or other electronics.

CARBURETOR TEMPERATURE SENSOR

Install the carburetor temperature sensor in the venturi area at the point where ice first begins to form. This is located after the main nozzle, before the throttle valve. You must remove the plug in the carburetor housing below the throttle valve. On 4-cylinder engines which use the Marvel Schebler MA-3 carburetors, this plug is located on the forward side. On 6-cylinder engines using the MA-4 carburetor, the plug is located on the rear. If your carburetor is not drilled and tapped for the plug, you must remove the carburetor from the engine and drill out the lead plug in the appropriate spot. Tap the hole with a 1/4-28 tap. Remove all chips and burrs before reinstalling.

Route either of the two wires to an electrical ground. Route the other wire to the general-purpose input of your choice. If you received a temperature sensor with **all black wires** (Dynon P/N 100413), you should find a 1k Ω resistor (color bands: brown, black, black, brown, brown; connect in either direction) in the package. Connect one end of this resistor to the +5V Excitation Circuit (pin 18) and the other end to the GP input you've connected the sensor to. If you received a sensor with

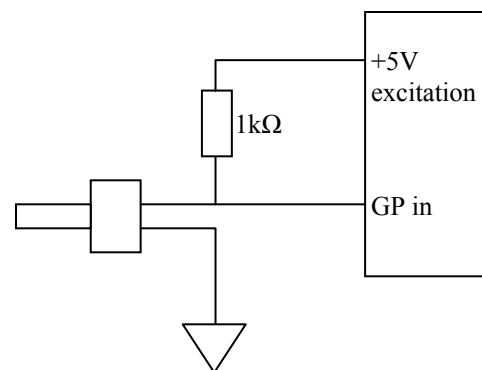

Connection for all black wire sensor (P/N 100413) only. No resistor needed for black/white wire sensor (P/N 100468).

black/white wires (Dynon P/N 100468), there will be no resistor in the package and you do not need to make any additional connections.

Be sure to configure the EMS-D10 to recognize the carburetor temperature sensor on the general-purpose input you've chosen as described in the General Purpose Inputs section on page 5-16.

FUEL LEVEL (RESISTIVE) SENSORS

You may connect up to two resistive fuel level sensors to the GP inputs. Generally, this should only be done if the plane has more than two tanks and the dedicated fuel level inputs are already used. Connect the output of the fuel level sensor to the desired GP input. Also, connect this same node to a 200Ω resistor (color bands: Red, black, black, black, brown; connect in either direction); the other end of which should be attached to the +5V Excitation Circuit. (Resistor values between 150Ω and 300Ω can be used if 200Ω is not readily available.)

Be sure to configure the firmware to recognize the fuel level sensor on the general-purpose input(s) you've chosen as described in the General Purpose Inputs section on page 5-16.

ROTAX CHT SENSORS

Crimp *bare* 1/4" female Faston terminals (6.3x0.8 according to DIN 46247) onto the ends of the wires connected to GP 1 (pin 4) and GP 2 (pin 22) on the EMS-D10. Locate the left-side CHT sensor screwed into the bottom side cylinder head 2; slide the Faston connected to GP1 input onto it. Locate the left-side CHT sensor screwed into the bottom side cylinder head 3; slide the Faston connected to GP2 input onto it.

You will find two 1.21kΩ resistors (color bands: brown, red, brown, brown, brown; connect in either direction) in the accessories package (Dynon P/N 100446-000) included with the EMS-D10. Connect either end of one of the resistors to the +5V Excitation Circuit (pin 18) and the other end to the wire connecting the left CHT sensor to pin 4. Repeat this with the right CHT sensor.

Pin	Color	Sensor	Function
4	Purple/blue	CHT L	GP 1
22	Purple/yellow	CHT R	GP 2

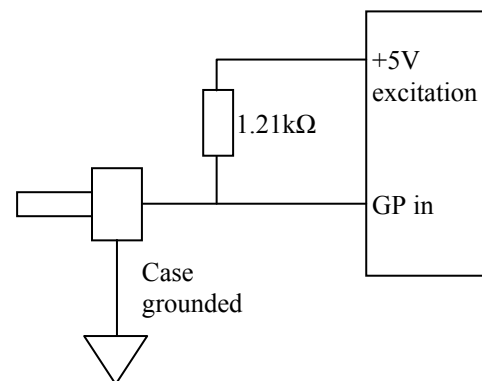

Be sure to configure the EMS-D10 to recognize the Rotax CHT sensors on the 2 general-purpose inputs as described in the General Purpose Inputs section on page 5-16.



TRIM AND FLAPS POSITION POTENTIOMETERS

Dynon Avionics does not sell trim or flaps position sensors. These are normally included with, or added on to, their respective servos.

Most flap and trim sensors are potentiometers (variable resistors) which require power and ground inputs, and supply an output that is a function of position. These potentiometers come in a variety of resistance ranges, but are typically 1kΩ, 5kΩ, 10kΩ, and 20kΩ. All of these values will work properly with the EMS-D10, as there is a calibration required, as described on page 5-6. Connect the 5V Excitation line from the EMS-D10 37-pin EMS connector to the +5V input on your trim/flap position sensor. Connect the ground input on the sensor to a ground common to the EMS-D10. Connect the output of the sensor to the desired GP input. You may connect up to three trim/flap sensors. For physical installation, refer to the instructions that came with your position sensor.

DB37 EMS Pin	EMS harness Color	Position Pot Function	Function
Desired GP input #	See chart on page 3-13	Position out (voltage)	GP
18	White/Red	+5V in	Position sensor power
Ground pin	Black	Ground in (common to EMS)	ground

If you are using the output from a Ray Allen servo or sensor, connect its white/orange wire to the Dynon 5V excitation line (pin 18), its white/blue wire to ground, and its white/green wire to your GP input of choice.

Be sure to configure the EMS-D10 to recognize the various sensors on the general-purpose inputs as described in the General Purpose Inputs section on page 5-16. Additionally, you will need to calibrate each flap/trim sensor as described on page 5-6.

COOLANT PRESSURE SENSOR

You will find two 1kΩ resistors (color bands: brown, black, black, brown, brown; connect in either direction) in the accessories package (Dynon P/N 100446-000) included with the EMS-D10. You will be using one of these resistors for proper installation of this sensor.

The Dynon-supplied coolant pressure sensor is a 0-30 psi sensor (Dynon P/N 100411-000). First, mount the pressure sensor to a fixed location using an Adel clamp or other secure method. The pressure sensor must *not* be installed directly to the engine due to potential vibration problems. Next, connect the sensor to the coolant line using appropriate hoses and fittings. Its pressure port has a 1/8-27 NPT pipe thread fitting; you may need adapters to connect to the pressure port on your engine. Locate (or drill and tap) the pressure port along the coolant line. This port must have a pressure fitting with a restrictor hole in it. This restrictor hole

DB37 EMS Pin	EMS harness Color	Function
Desired GP input #	See chart on page 3-13	GP
18	White/Red	5V supply to 1kΩ resistor
Ground pin	Black	Ground in (common to EMS)

ensures that, in the event of a sensor failure, coolant leakage rate is minimized, allowing time for an emergency landing.

Crimp a standard ¼” female Faston onto one of the ground wires (see the Grounding section on page 2-2) coming from the 37-pin harness. Crimp another ¼” female Faston onto both the wire that corresponds to the desired GP input and a 1kΩ resistor (color bands: brown, black, black, brown, brown; connect in either direction), or splice the resistor into the GP input line elsewhere on the run. Push the two Fastons onto the two terminals on the fuel pressure sensor. Polarity is not important. Connect the other side of the 1kΩ resistor (color bands: brown, black, black, brown, brown; connect in either direction) to the 5V Excitation Circuit, pin 18, as shown in the diagram.

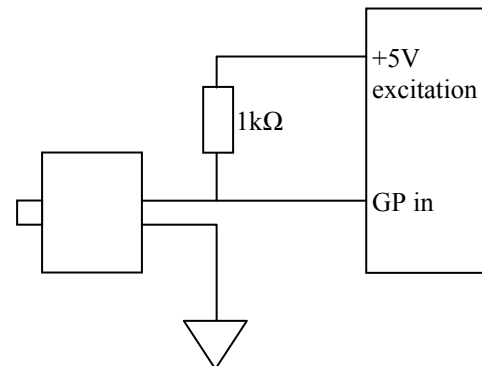

- ❗ Due to vibration issues, never connect the pressure sensor directly to engine.
- ❗ If you use Teflon tape or other seal, ensure the sensor casing still maintains a good connection to ground.

COOLANT TEMPERATURE SENSOR

You will find two 1kΩ resistors (color bands: brown, black, black, brown, brown; connect in either direction) in the accessories package (Dynon P/N 100446-000) included with the EMS-D10. You will be using one of these resistors for proper installation of your coolant temperature sensor.

The coolant temperature sensor needs to be installed according to the directions of your engine’s manufacturer. Dynon Avionics sells temperature sensors with both 5/8-18 UNF (Dynon P/N 100409-001) and 1/8-27 NPT (Dynon P/N 100409-000) threads; these are the same as those used by the oil temperature inputs. If neither of these threads matches those in your coolant line, you will need to use adapters or drill/tap your own. Using a crush washer between the sensor and the mating line, screw the sensor into the fitting. Do not over tighten.

Route the wire from the desired GP pin on the 37-pin harness to where the coolant temperature sensor is mounted. When routing the wires, make sure that they are secured, so they will not shift position due to vibration. Strip ¼” of insulation off the end of the wire. Crimp a #10 ring terminal onto the end of the wire and a 1kΩ resistor (color bands: brown, black, black, brown, brown; connect in either direction), or splice the resistor into the GP input line elsewhere on the run. Ensure that a good connection is made between the wire and the connector (and resistor, if spliced in at that point). Unscrew the

DB37 EMS Pin	EMS harness Color	Function
Desired GP input #	See chart on page 3-13	GP
18	White/Red	5V supply to 1kΩ resistor

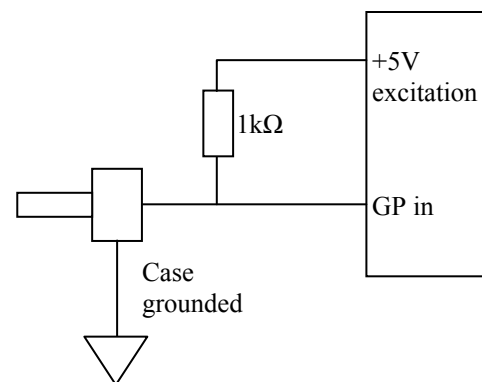



nut from the stud on the coolant temperature sensor. Slip the ring terminal onto the stud and secure the nut over it. Connect the other side of the 1k Ω resistor (color bands: brown, black, black, brown, brown; connect in either direction) to the 5V Excitation Circuit, pin 18, as shown in the diagram.

Rotax Pre-installed Coolant Temperature Sensor: Wire the coolant temperature sensor in the same way as shown above for the Dynon-supplied sensor. Configure the Sensor Type as **4**, as shown on page 5-17.

GENERAL PURPOSE TEMPERATURE SENSOR

You may connect an OAT probe and configure it as a general purpose temperature measurement (e.g., for cabin temperature). Refer to the Outside Air Temperature Sensor section on page 3-13 for installation information and to the General Purpose Inputs section on page 5-18 for configuration information.

Contacts

Dynon Avionics does not sell contacts or switches.

Contacts are used for a variety of purposes, such as monitoring canopy closure. The EMS firmware reads the state of two contact inputs, reporting whether each input is open (no connection to ground) or closed

(connection to ground). You may connect up to two contacts you would like to be monitored by the EMS-D10. You must ensure that when closed, the contact connects to a ground common to the EMS-D10. The voltage on the contact inputs must not exceed 15V.

The Contacts Configuration section on page 5-19 describes the details of configuring the contacts, including giving them custom names.

HS34 If more than two contacts are needed, the optional HS34 includes four additional contacts. Connection and configuration of HS34 is the same as for contacts connected directly to the EMS-D10.

Pin	Color	Function
9	Brown/blue	Contact 1
10	Brown/yellow	Contact 2

General Purpose Thermocouple

You may configure the EMS-D10 to monitor one J or K type thermocouple. Dynon Avionics does not sell a specific general purpose thermocouple probe for this purpose. However, our standard EGT and CHT probes will work, as will any other J or K type thermocouple.

Dynon Avionics sells both J and K type thermocouple wire which may be used to connect the desired thermocouple to the EMS-D10. Ensure you order the correct wire type for the thermocouple you intend to use. Crimp a female D-sub pin on the end of each wire, and plug them into the D37 connector. Polarity is important, so ensure that you are routing the positive side (yellow for K-type; white for J-type) of the thermocouple to pin 27 on the 37-pin harness, and the negative side to pin 28.

Pin	Color	Function
27	Not supplied	Thermocouple + (yellow or white)
28	Not supplied	Thermocouple - (red)

4. INSTRUMENT INSTALLATION

This section provides you with the information needed to physically and electrically install the EMS-D10.

Power Bus Wiring

Connect pin 1 on the 37-pin harness to your avionics bus through an appropriately sized fuse or circuit breaker. Connect pin 3 to electrical ground on your avionics bus. Pins 1 and 3 form the primary current path for supplying the EMS-D120 with power; ensure that you are very familiar with the Grounding section on page 2-2.

EMS DB37 Pin#	Color	Function
1	Red	Power (10-30 V)
2	Yellow	Keep Alive (10-30V, low current)
3	Black	Ground

Dynon Avionics recommends not connecting the Keep Alive wire when the EMS-D10 is connected to a DSAB network and/or GPS. Keep Alive is only used in a standalone EMS installation to keep the clock running when the unit is powered off.

Serial Communication Cables

! **More Information Is Available Online:** Serial communication to non-Dynon devices, and interfacing of other devices in general can be involved and detailed. This Installation Guide is intended to provide general installation advice for the most common devices and situations. Dynon’s Documentation Wiki provides enhanced, extended, frequently updated online documentation contributed by Dynon employees and customers at wiki.dynonavionics.com.

The EMS-D10 has one RS-232 serial port that can be used for several purposes. This serial port can only be configured for one purpose at a time. This serial port is used for:

- Connecting to a PC, and using the Dynon Avionics Product Support Program to perform firmware upgrades, configure checklists, and download internal logs. The Help Files of the Support Program provide detailed instructions on these functions. The latest version of the Product Support Program is available on the Dynon web site at downloads.dynonavionics.com.
- Connecting serial devices such as a GPS receiver or an SL30.
- “Streaming” real-time EMS engine data to an external serial device for recording. For data formats and other information, see the Appendix in the EMS-D10 Pilot’s User Guide. Note that for the purposes of logging data, version 5.0 of EMS-D10 firmware added internal data logging and retrieval via the Dynon Support Program.

HS34 When an optional HS34 Expansion Module is connected to your Dynon DSAB network, all GPS and NAV radios must be connected to it. This simplifies the connection and usage of multiple serial devices. The HS34 also provides interfaces to non-serial devices such as those with only analog and ARINC-429 interfaces.



PC USB CONNECTION

If you do not have a serial port on your PC, you may use a USB-to-Serial adapter to connect the EMS-D10 to your PC's USB port. You may purchase an adapter from us, Radio Shack, or many computer stores. If you are using **Windows 2000 or XP**, ensure that the adapter driver CD is inserted in your PC before plugging the adapter into the USB port for the first time. If you are using **Windows Vista**, ensure that you are connected to the Internet and do *not* use the driver CD; the operating system will download the correct driver. Also, do not have your EMS-D10 plugged into the USB-to-Serial adapter while installing the driver.

EMS SERIAL HARNESS

On the EMS 37-pin wiring harness available from Dynon, there are three wires bundled together, colored orange, yellow, and black, and terminating in a standard D-sub 9-pin female connector. If you did not purchase a harness from Dynon, obtain a 9-pin D-sub connector and make the three connections shown in the table.

EMS DB37 Pin#	DB9 Pin#	Color	Function
11	2	Orange	EMS transmit / device receive
12	3	Yellow	EMS receive / device transmit
30	5	Black	RS232 Ground

To verify proper communication between the EMS-D10 and the PC, use the Dynon

Avionics Product Support Program's "Detect Firmware Version" function. Download the latest version of the Support Program from the Dynon Web Site at downloads.dynonavionics.com.

SL30 and/or GPS connection

Depending on the number and types of Dynon units you own, you have several options for connecting a GPS unit and/or Garmin/Apollo SL30 to your Dynon system. The GPS can be used as a data source for the EFIS, HSI, and Fuel pages, as well as Dynon's EFIS-based Autopilot. The SL30 can be used as a VOR, localizer, or ILS (localizer + glideslope) source for the HSI. If you wish to connect a GPS and/or SL30 to your Dynon system, read the section below which corresponds to your set of Dynon products.

HS34 If your system has an HS34, it is *required* that all GPS and NAV devices are connected to the HS34. The EMS-D10 does not support directly connected GPS and NAV devices when an HS34 is installed in the system. Refer to the HS34 Installation and Configuration section in your EFIS-based product's Installation Guide for device connection details.

GPS units known to work
AvMap EKP-IV (v2.06.116R, NMEA set to "processed")
Bendix/King Skymap (set to AR NAV 9600 output)
Garmin 96, 96c, 150XL, 195, 196, 295, 296, 396, 400*, 420*, 430*, 430W*, 496, 500*, 520*, 530*, 530W*, GX60, GX65
Lowrance handhelds
<i>* Do not output time over serial; ARINC connection via HS34 required to receive time.</i>
<i>A frequently updated list of compatible GPS units and settings is available at our Documentation Wiki at wiki.dynonavionics.com.</i>



To use the GPS-related features on your EFIS and/or EMS, your GPS must output either “aviation format” or the following NMEA sentences in its serial stream: \$GPRMC, \$GPRMB, \$GPGGA, and one of \$GPBOD or \$GPAPB. You must also have a supported cable that exposes your GPS’s serial transmit line. If you own a Garmin 430 or 530, in the UNITS/MAGVAR option, set the MAGVAR to AUTO. The EMS-D10 auto-detects most GPSs, but may require a manual setting for some. This is true for communication with at least the Garmin 480 and maybe others such as the GX50, and GX60, and Bendix/King Skymap IIIc. From the EFIS menu, enter SETUP >HSI >EFIS_SERIAL; from the EMS menu enter SETUP >GLOBAL >EMS SERIAL. In that menu select the INPUT to be AVIATION and the BAUD RATE to be 9600.

GPS units with limited functionality	
AnywhereMap	Does not output all needed sentences. Time output is wrong.
Garmin (Apollo) GNS 480	Possibly works with latest Dynon product firmware, but untested. Requires manual configuration. See note at left. Fully compatible via ARINC into optional HS34.
<i>A frequently updated list of compatible GPS units and settings is available at our Documentation Wiki at wiki.dynonavionics.com.</i>	

The following connection schemes assume that the external devices share a common ground with the Dynon product(s). If your GPS is battery powered, and not normally connected to aircraft ground, you must connect the ground pin on its serial output to a ground common to the EMS-D10.

When a Dynon product is connected to a GPS, it will synchronize its Zulu clock to the time reported by the GPS. However, some GPSs, such as the Garmin 430 and 530, do not report time in their serial output stream. Dynon products have no way to synchronize to these GPSs’ clocks.

Read the section below that corresponds to your configuration of Dynon products. All EFIS-based product configurations direct you to connect your external device to PC serial receive (pin 22) on your Dynon EFIS product. You may make this connection at any point between pin 22 on the EFIS DB25 and pin 3 on the connected DB9 EFIS/PC connector. If you purchased your harness from Dynon Avionics, it may have a yellow/green wire provided for this purpose.

IF YOU OWN ONLY AN EFIS-D10A OR EFIS-D100

Connect the GPS or SL30 transmit line into pin 22 on the DB25 connector. This is the same Serial Rx line that is used for firmware updates. You will need a way to disconnect this when you plug your EFIS into a PC for firmware updates and checklists.

If you have both a GPS unit and an SL30, you will need to wire the two transmit lines to a 3-way switch; connect the output of the switch into pin 22 on the EFIS harness. You will use this switch to toggle between GPS, SL30 and a disconnected state. The HSI auto-detects the switched instrument and will change modes automatically.

IF YOU OWN TWO EFIS-ONLY UNITS

When 2 EFIS-only units are connected via DSAB, only the DSAB Bus Master’s serial port is active.



If you have only one serial device (GPS or SL30), connect its transmit line to pin 22 on the DB25 connector of the EFIS that you have chosen to be the Bus Master. This is the same Serial Rx line that is used for firmware updates. You will need a way to disconnect this when you plug your EFIS into a PC for firmware updates and checklists.

If you have both a GPS unit and an SL30, you have two options:

Wire the 2 devices' transmit lines to a switch, allowing you to select the serial device active on the HSI screen.

Do not connect the two EFIS units together via DSAB. You may then wire one device to one EFIS' pin 22, and the other device to the other EFIS. Of course, the EFIS devices would be independent and unable to share GPS or SL30 data.

You will need a way to disconnect both lines when you plug your EFIS into a PC for firmware updates and checklists.

IF YOU OWN ONLY AN EMS-D10 OR EMS-D120

We recommend that you only connect a GPS to an EMS-only system; without the magnetic heading from an EFIS, the HSI page will not be functional. Connect the GPS transmit line to pin 19 on the EMS DB37 connector. This connection will give you fuel endurance information (range, MPG, etc) on the fuel page and GPS information only (track, ground-speed, course, etc) on the HSI page. There is no need to break this connection when doing PC updates.

IF YOU OWN AN EMS AND AN EFIS (NOT FLIGHTDEK-D180)

First, ensure that your EMS and EFIS are connected as described in Dynon Smart Avionics Bus (DSAB) Wiring on page 4-7.

If you only have either the GPS or SL30 (but not both), connect the GPS or SL30 transmit line to pin 19 on the EMS DB37 connector. This is labeled "Aux Serial Receive." With either a GPS or an SL30 connected, you are able to display an HSI on either product; with a GPS connected, you are able to display EMS fuel economy displays.

If you have a GPS *and* an SL30, connect the GPS to pin 19 on the EMS DB37 connector. Connect the SL30 to pin 22 on the EFIS DB25 connector. This will allow you to flip between GPS and SL30 inputs. You can use either the SL30 or GPS as the NAV source on the EFIS product. You will need to disconnect the SL30 from the EFIS when doing software updates.

IF YOU OWN ONLY A FLIGHTDEK-D180

Connect the SL30 unit to pin 22 on the EFIS DB25 connector, and the GPS to pin 19 on the EMS DB37 connector. You can display either source on the HSI using the softkeys. You will need to disconnect the SL30 from the EFIS when doing software updates.

IF YOU OWN A FLIGHTDEK-D180 AND AN EFIS

Connect the SL30 unit to pin 22 on the FlightDEK's EFIS connector (vertical DB25) and the GPS to pin 19 on the EMS DB37 connector. You can display either source on the HSI, and you can display either on the standalone EFIS as well (provided you have connected the DSAB A & B lines from the FlightDEK-D180 to the standalone EFIS product). You will need to disconnect the SL30 from the FlightDEK-D180 when doing software updates.



Do not connect any serial devices to the secondary EFIS device. It will only display data from the serial devices connected to the master FlightDEK-D180.

External EMS Warning Light

EMS DB37 Pin 29 can be wired and configured as an external warning light, or alternatively, to automatically control cabin light levels in sync with the screen brightness of the Dynon instruments.

To wire EMS DB37 Pin 29 as an external warning light, you may connect any standard LED or incandescent lamp (1.5 watts maximum), used during EMS-related alarm conditions.

Ensure that the LED or lamp is designed for the voltage of your system. Mount it to your panel according to its recommendations. Connect one of the lamp's leads to your plane's power. Connect the other lead to pin 29 on the EMS-D10 37-pin wiring harness. During an alarm condition, this pin is connected to ground, causing current to flow through the lamp.

To configure EMS DB37 Pin 29 as an external warning light, enter the EMS menu by pressing any button beneath an EMS main page. Press MORE > SETUP > GLOBAL. Press DOWN ▼ to select ALARM CONFIG and press SEL. LGT BHVR: ACK SOLID configures the external alarm light to remain on (solid) when the alarm condition is acknowledged. LGT BHVR: ACK CLEAR configures the external alarm light to go off when the alarm condition is acknowledged.

Verify correct operation of the external EMS warning by using the test function in the GLOBAL menu. Enter the EMS menu by pressing any button beneath an EMS main page. Press MORE > SETUP > GLOBAL. Press DOWN ▼ to select ALARM CONFIG and press SEL. Select TEST ALARM LIGHT and follow the instructions to test external light functionality.

Dimmer mode function is generally used only by Original Equipment Manufacturers (OEMs). In dimmer mode, the output of EMS DB37 Pin 29 is a Pulse Width Modulation (PWM) signal proportional to the screen brightness setting of the Dynon instruments. To configure EMS DB37 Pin 29 for dimmer mode, enter the EMS menu by pressing any button beneath an EMS main page. Press MORE > SETUP > GLOBAL. Press DOWN ▼ to select ALARM CONFIG and select LGT BHVR: DIM OUTPT.

EMS DB37 Pin	Color	Function
29	Yellow/Green	External warning light / Dimmer control

Audio Alert Outputs

The EMS-D10 has an audio alarm outputs for sounding EMS-related alarms. The Audio Alert output from the EMS-D10 should be connected to the outside terminal of a 10 kΩ variable resistor (not included).

EMS DB37 Pin#	Color	Function
31	White/Orange	EMS Audio Alert Output

HS34

AP74

If you have purchased and installed an HS34 and/or an AP74, we recommend that you only connect the HS34 audio output *or*

AP74 audio output (but *not* both) to your audio panel. The HS34 or AP74 audio output provides voice and tone outputs for both EMS- and EFIS-related alerts. When the HS34 or AP74 audio output is connected, it is not necessary to connect the audio outputs of other Dynon Avionics devices. Connecting the HS34 audio output and the AP74 audio output in parallel *will result in distorted audio*. Refer to the HS34 Wiring section in your EFIS-based Installation Guide for more information.

Ensure that audio outputs are connected similar to the following diagram. The 10 k Ω variable resistor can be obtained from Radio Shack (P/N 271-1715) or other electronics suppliers.

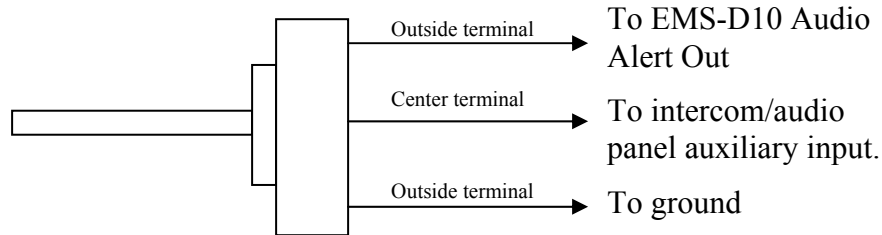

To set the volume of the engine alarms, you will need your EMS-D10 powered on and the alarm output wired as described above. Enter the EMS menu by pressing any button beneath an EMS main page. Press MORE > SETUP > GLOBAL. Press DOWN ▼ to select ALARM CONFIG and press SEL. Scroll down to select TEST ALARM AUDIO. Press and hold SEL to generate a tone on the audio output. Adjust the variable resistor until the volume in the intercom or audio panel is at an acceptable level.

Dynon Smart Avionics Bus (DSAB) Wiring

The Dynon Smart Avionics Bus is the only way Dynon products can communicate with one another, providing features such as data sharing and alarm notification. DSAB is a multi-drop bus, meaning several devices can be connected to the same 2 wires. If you have an EMS and EFIS product connected via their serial ports through a null modem, you should disconnect this legacy interface.

EMS DB37 Pin#	Color	Function	EFIS DB25 Pin#
34	Blue	DSAB-B	5
35	Green	DSAB-A	4
36	Blue	DSAB-B	
37	Green	DSAB-A	

You must connect the DSAB A connection (pin 35 or 37) on the EMS DB37 harness to the DSAB A connection for the next device in the chain. Do likewise for the DSAB B connection (pin 34 or 36). Some products – like the EFIS series and the HS34 – have only one pair of DSAB connections on the back connector; other products – like the EMS series – have two pairs, for wiring convenience. If you have 3 or more devices in your system, and one of them is an EMS-series product, we recommend that you locate it in the middle of your wiring scheme as shown below. This eliminates the need to splice two wires together.

- ❗ Wherever possible, ensure that the two DSAB wires (DSAB A and B) are run as a twisted pair. This minimizes the system's susceptibility to electrical noise.

Refer to the DSAB Configuration chapter on page 6-1 for detailed instructions on configuring your DSAB network.

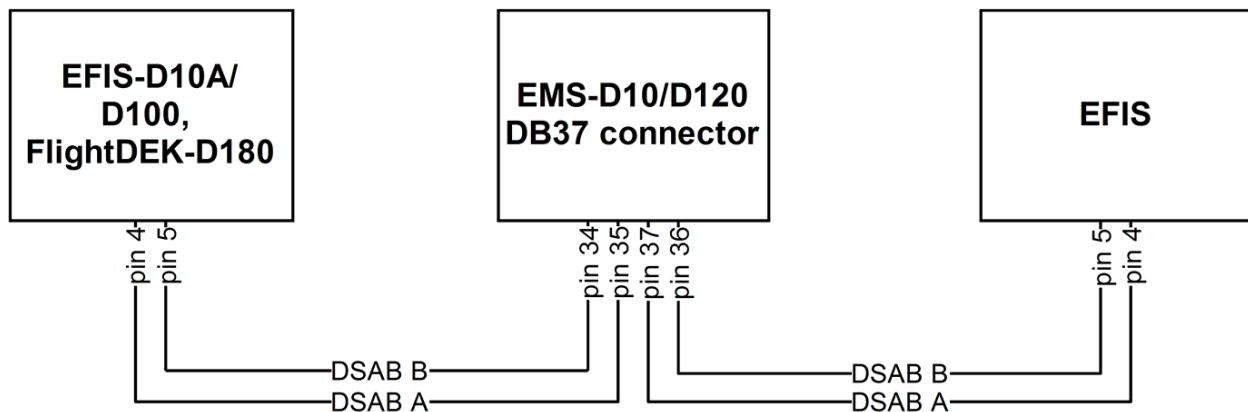

Panel Location and Mounting

The diagram at right shows the outside dimensions of the front bezel of the EMS-D10. Note that the instrument is about seven inches deep and the supplied harness extends three inches more. Use the dimensions (in inches) found on the diagram to plan for the space required by the instrument. Take the following considerations into account when selecting a mounting location for the EMS-D10.

Avoid placing the instrument near heater vents or any source of extremely hot or cold air. Keep in mind that the air surrounding the EMS-D10 during operation may be no warmer than 50 °C to ensure accurate operation. Plan a panel location that allows convenient viewing of the instrument with no obstruction.

You have two options for mounting the EMS-D10 into your panel: standard or flush. You may use the optional flush-mount bracket, allowing the face of the EMS-D10 to be flush with your panel. If you opted to receive the flush mount bracket, please skip to Option 2 below. If you opted not to receive this bracket and wish to perform the standard install, follow the options in Option 1 below.

OPTION 1: NO MOUNTING BRACKET

Using this option, you will be mounting the EMS-D10 directly into your panel. The front bezel of the unit will extend beyond the plane of your panel by 0.8”.

Installation of the EMS-D10 main unit should only be completed once all other physical and electrical installations have been performed. This will ensure that last-minute adjustments will not have to be made with the EMS-D10 mounted in the panel.

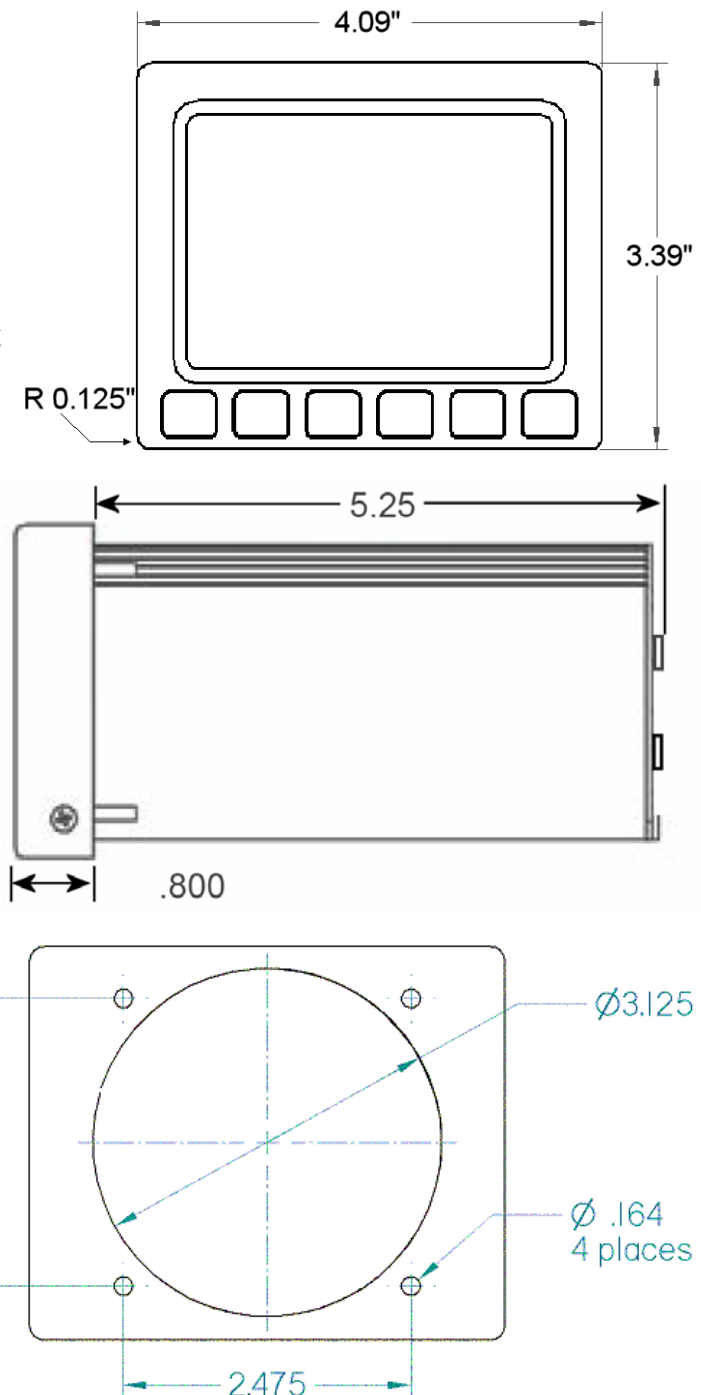

The diagram above shows the dimensions expected for the proper installation of the EMS-D10 into your panel using no mounting bracket. All units are in inches. Push the EMS-D10 through the main panel hole. The four studs on the back of the EMS-D10 will fit into the four mounting holes having dimensions listed in the diagram. Place one of the four supplied washers on each stud before pushing the EMS-D10 into place in the panel, putting the washers in between the EMS-D10 and the panel. Place one of the 4 supplied mounting nuts on the end of each of the 4 studs protruding from the back of the panel. Secure the nuts tightly against the panel to complete the installation.

OPTION 2: FLUSH-MOUNT BRACKET

Make a rectangular cutout in your panel, ensuring that it allows the front panel of the EMS-D10 to fit. The cutout required should have the dimensions 4.09" wide by 3.39" tall with corner radii of 0.125". You also need to drill four 0.164" holes in your panel at the four locations shown on the diagram below (two above and two below the rectangular cutout). Install #6 plate nuts on the back side of the bracket. Place one of the supplied washers onto each of the four mounting studs on the EMS-D10 and then slide the flush mount bracket over the EMS-D10. The bracket should wrap around the bezel of the EMS-D10. Place one of the 4 supplied nuts on each of the 4 studs and tighten the nuts. The EMS-D10/bracket can now be installed from behind your panel using the #6 screws through the previously drilled holes.

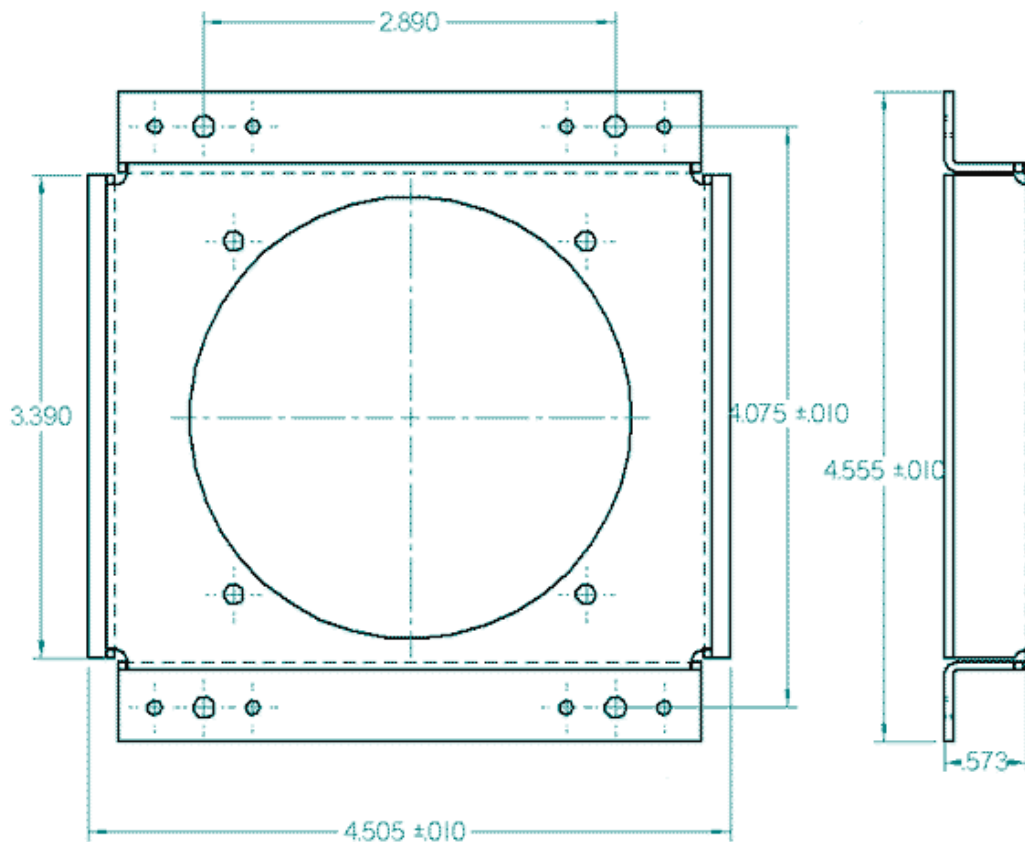

5. EMS CONFIGURATION

Once the engine sensors are physically installed, you must configure the EMS-D10 to recognize and correctly display all engine parameters. To interact with the EMS-D10 menu system, use the 6 buttons on the front panel. The buttons are numbered one to six, left to right. With the instrument powered on and the EMS main page displayed, press any button (except the leftmost and rightmost buttons, reserved for hotkey screen switching) beneath the EMS main page to bring up the menu. Press MORE to see the next menu, and then SETUP to enter the setup menu.

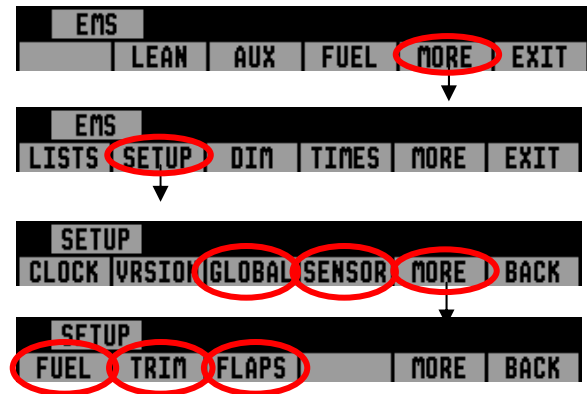

Pressing MORE will toggle through the various SETUP options. For the purposes of installation, you will be dealing with the GLOBAL, SENSOR, FUEL, TRIM (if installed) and FLAPS (if installed) options.

Full-Page Setup Menu Overview

When in full-page menus, follow these tips to navigate through them:

Use the DOWN ▼ and UP ▲ buttons to scroll up and down through menu items.

Use the SEL ► button to enter a submenu (the white area) as shown at right.

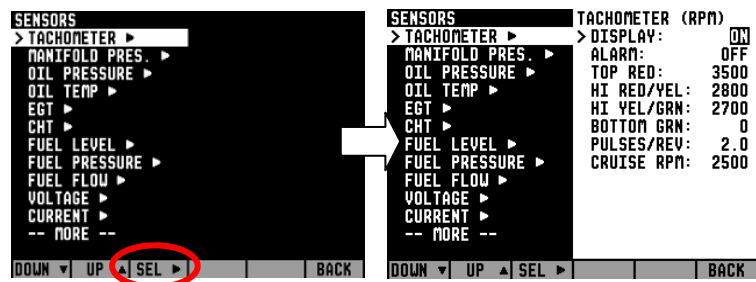

When in a submenu, press UP ▲ and DOWN ▼ to scroll through the available options.

If you have selected a value that can be toggled between a small number of values (like ALARM status), the SEL ► button will appear. Press SEL ► to toggle the value through its possible states. In the case of ALARM status, pressing SEL ► would cycle from OFF to SELF-CLEAR to LATCHING and back to OFF.

If you have selected a value that can be incremented and decremented (like the HI YEL/GRN color boundary), the INC+ and DEC- buttons will appear. Press INC+ to increase the value and DEC- to decrease it.

The EMS-D10 comes with most displays defaulted to ON. If you have not installed a given sensor or have reason to not display it, set the DISPLAY parameter to OFF.

The EMS-D10 supports multiple types of sensors for some functions. For any input which supports more than one type of sensor, you must select a “sensor type” in its configuration section. This information is used by the EMS-D10 to determine which sensor is installed for a given function. The default sensor type, “1,” is the most common Dynon-supplied sensor for

each function. The various supported sensors and their types are described below, starting at page 5-8.

Alarm and Color Threshold Configuration

In the various sensor setup menus, you will be configuring the alarms and color thresholds. Below is an introduction to the principles used.

If you have configured EMS > GLOBAL > ENGINE TYPE to ROTAX, then the color thresholds for the Tachometer and Oil Temperature are automatically set in accordance with manufacturer specifications.

Alarms for any given sensor can have three different modes of operation. They are:

OFF – When the selected sensor enters the red portion of its analog gauge, no alarm will be sounded. Use this mode if you have not installed the selected sensor or do not wish to be alerted when its value is beyond the norm.

SELF-CLEAR – When an alarm condition occurs for the selected sensor, an alarm will be displayed (and sounded, if the audio alert connection to the intercom is made). If the given parameter enters normal values (i.e., comes out of the red), the alarm will be cancelled.

LATCHING – The alarm will continue to be displayed, even if the condition has returned to normal values again.

AOA (appears only on EMS Contact 1 and EMS Contact 2) – When EMS Contact 1 or EMS Contact 2 is activated, the AOA alarm in the EFIS (if installed and connected via DSAB) is triggered; the resulting alarm depends on how the EFIS AOA alarm is configured (EFIS TONE, HS34 TONE, or HS34 VOICE).

All displayed analog bars have color thresholds which must be set. Navigate to each threshold to increment or decrement it. Each number represents the value – in the units of the displayed parameter. So, in the picture above, the top section of the oil pressure analog bar is set to 99 PSI; the threshold between the upper portion of red and the upper portion of yellow is set to 95 PSI; and so on. If an alarm for a given sensor is enabled (either SELF-CLEAR or LATCHING), the alarm will trigger at the red/yellow boundaries.

Some sensors have color thresholds on the high and low side; others have thresholds on only one side or the other. This depends on the individual value being displayed and whether its being too high or too low is noteworthy. Whenever a value is in normal operating conditions (green on the analog bar), its displayed numeric value will be white. When any value enters a yellow or red zone on its analog bar, the respective numeric value will change colors accordingly.

When you modify one value, it will not “push” another value up or down. So, in the example above, you would not be able to increment the HI RED/YEL parameter beyond 6.8 until you increased the TOP RED parameter. Likewise, you would not be able to decrement the HI RED/YEL value below 6.2 until you decrease the HI YEL/GRN parameter.

SENSORS		OIL PRESSURE (BAR)	
TACHOMETER ▶	> DISPLAY:	ON	
MANIFOLD PRES. ▶	ALARM:	OFF	
> OIL PRESSURE ▶	TOP RED:	6.8	
OIL TEMP ▶	HI RED/YEL:	6.6	
EGT ▶	HI YEL/GRN:	6.2	
CHT ▶	LO GRN/YEL:	1.4	
FUEL LEVEL ▶	LO YEL/RED:	1.0	
FUEL PRESSURE ▶	BOTTOM RED:	0.0	
FUEL FLOW ▶	SENSOR TYPE:	1	
VOLTAGE ▶			
CURRENT ▶			
-- MORE --			
DOWN ▼	UP ▲	SEL ▶	BACK



To disable alarms before engine start, enter the EMS > SETUP > GLOBAL > ALARM CONFIG menu. Set PWR ON ALARMS to OFF. With this parameter set to “OFF”, all alarms are suppressed whenever ALL of the following conditions exist:

RPM less than 400

Oil pressure less than 20 PSI

First five minutes after master instrument power applied

All alarms are initialized when any of the above conditions are exceeded.

Global Parameters Setup

When in the SETUP menu, press GLOBAL to bring up the full-screen menu seen at right. During installation, you only need to deal with the items under the INSTALL SETUP section. During install, you may want to change the units to the setting that is convenient for you. If you are not the intended pilot using the instrument, he or she may easily change units to whatever they desire without affecting calibration or configuration. Refer to the EMS-D10 Pilot’s User Guide for more detailed information about the PILOT SETUP and SCREEN SETUP sections of the GLOBAL menu.



Press DOWN ▼ until you have selected the item, # OF CHT. Press SEL ▶ until the number shown reflects the number of cylinder head temperature sensors installed on the engine. For Rotax 9-series engines, select 2 to indicate the fact that the EMS will be monitoring the left and right pairs of cylinders.

Press DOWN ▼ to select the item, # OF EGT. Press SEL ▶ until the number shown reflects the number of exhaust gas temperature sensors installed on the engine.

Press DOWN ▼ to select the item, CYL DISP. Press SEL ▶ to toggle between SPLIT and COMBD. The split display presents CHTs and EGTs in separate locations as horizontal bars, and is available for 2 and 4 cylinder displays. The combined display presents CHTs and EGTs in the same location with EGTs as horizontal bars, and CHTs as ticks on the bars.

Press DOWN ▼ to select the item, # OF FUEL TANKS. Press SEL ▶ until the number shown reflects the number of fuel tanks included on the aircraft.

If you need to adjust the Hobbs time on the EMS-D10 to match that of your engine, press DOWN ▼ to select the item, SET HOBBS TIME. Press SEL ▶ to enter the Hobbs time setting submenu. Press SEL ▶ to select the desired digit and then DOWN ▼ or UP ▲ to change the value. When you are finished, press BACK.

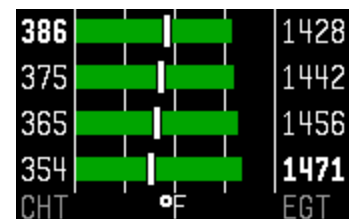

Combined display

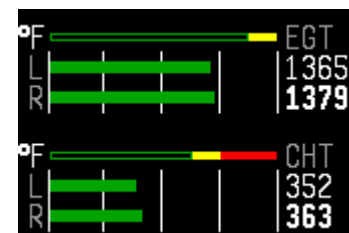

Split display



If you need to adjust the tachometer time on the EMS-D10 to match that of your engine, press DOWN ▼ to select the item, SET TACH TIME. Press SEL ► to enter the tachometer time setting submenu. Press SEL ► to select the desired digit and then DOWN ▼ or UP ▲ to change the value. When you are finished, press BACK.

Engine Type Configuration

Within the GLOBAL menu, press DOWN ▼ until you have selected ENGINE TYPE. Press SEL ► to toggle between LY/CON, ROTAX, and OTHER.

ENGINE TYPE: LY/CON

Setting ENGINE TYPE to LY/CON enables a percent power display for normally aspirated/non-turbocharged Lycoming or Continental engines. Press DOWN ▼ to select HP RATING and use the INC+ and DEC- buttons to set the value to the actual horsepower rating for your engine. Given the horsepower rating, an OAT, fuel flow, and altitude (from a connected EFIS-based product or GPS), the EMS-D10 will calculate percent power and lean-of-peak/rich-of-peak status, displaying both next to the Manifold Pressure gauge.

! For percent power status to be calculated as accurately as possible, TACHOMETER (RPM) HI RED/YEL should be set to the RPM value specified by the Engine Manufacturer. (This is commonly referred to as “Redline”).

If you do not have a fuel flow sender, the EMS-D10 will still display a percent power reading based on rich-of-peak calculations only. During lean-of-peak operation, percent power is displayed but is incorrect. While you are in LEAN mode, percent power is not displayed.

ENGINE TYPE: ROTAX

Setting ENGINE TYPE: to ROTAX pre-configures some settings for a Rotax 912 engine. Rotax 914 engines must be manually configured using ENGINE TYPE: OTHER. A percent power reading will not be displayed, but the EMS-D10 will automatically configure and dynamically change the oil temperature and tachometer scales and alert thresholds in accordance with Rotax’s recommended ranges, described in detail below.

RPM / TACHOMETER for Rotax 912:

When OIL TEMP < 120°F, the TACHOMETER displays these ranges:

- 0-1400 and 4000-6000 RPM in RED
- 1400-1800 and 2500-4000 RPM in YELLOW
- 1800-2500 RPM in GREEN

When OIL TEMP > 120°F, the TACHOMETER displays *different* ranges:

- 0-1400 and 5800-6000 RPM in RED
- 1400-1800 and 5500-5800 RPM in YELLOW
- 1800-5500 RPM in GREEN

At 0 RPM, the LOW RPM ALARM is inhibited. When RPM advances above 0, the LOW RPM ALARM is inhibited for 10 seconds. The HIGH RPM ALARM is always active.

OIL TEMP Gauge for Rotax 912:

When OIL TEMP < 190°F, the OIL TEMP gauge displays these ranges:

- 100-120 and 230-266°F in YELLOW
- 120-190°F in GREEN *if OIL TEMP has been above 190°F “more recently” than OIL TEMP was below 120°F*; otherwise 120-190°F is displayed in BLACK OUTLINED IN WHITE
- 190-230°F in GREEN
- 266-280°F in RED.

When OIL TEMP is > 190°F, the OIL TEMP gauge will display *different* ranges:

- 100-120 and 230-266°F in YELLOW
- 120-230°F in GREEN
- 266-280°F in RED

ENGINE TYPE: OTHER

For all other engine types, select OTHER. Currently, the EMS-D10 calculates percent power only for normally-aspirated Lycoming or Continental engines. Dynon Avionics will consider adding more engine types to our percent power calculations. If your engine is not currently supported and you would like to see it considered for possible inclusion, please send your engine’s power chart to: betatest@dynonavionics.com.

Fuel Level Calibration

Prior to calibrating your fuel tanks, ensure that you have made the correct fuel level sensor type selection as described on page 5-11.

Enter the EMS menu by pressing any button below an EMS main page and pressing MORE > SETUP > MORE > FUEL. You are presented with the screen shown below. The menu reflects the number of fuel tanks selected in the Global Parameters Setup, as described on page 5-3. If you do not see the correct number of tanks here, go back to the GLOBAL section of the SETUP menu and set the correct number of tanks.

Begin with empty tanks and be ready to fill them to capacity with an accurate way of adding fuel in defined increments (i.e. a standard gas pump gauge). Orient your plane into level flight attitude, and repeat the following steps for each tank you wish to calibrate.

Use the DOWN ▼ or UP ▲ buttons to select the tank that you wish to calibrate, and press SEL ►.



Enter the *approximate* number of gallons or liters the tank can hold. It is not necessary to be precise. This number is only used to determine reasonable fuel addition increments in the next steps. Press NEXT. Once you have confirmed that the tank you are calibrating is empty, press START. Follow the on-screen instructions until the completion of your fuel calibration.

At the completion of your fuel level calibration, the EMS-D10 will present you with a table of values in the format “[pour #]: [mV] [gallons]”. Ensure that the mV values (just after the colon) change throughout the range of pours. Also, it is highly advised that you create a backup of your EMS-D10 via the Dynon Product Support Program as soon as possible. This will ensure that the fuel calibration data is backed up, reducing the likelihood that you’ll need to repeat the process. Refer to the Dynon Product Support Program help file for more details on this process. Keep the firmware backup file in a place on your computer where you can easily find it again.

In addition to calibrating your fuel tanks, you may make a few settings that will enhance the functionality of the fuel computer. First, entering the FULL VALUE menu will allow you to configure the total amount of fuel available between all your tanks. This is used to calculate fuel remaining and other values, as well as allowing you to reset the fuel computer to a full fuel value with one button press. Likewise, the PRESET VALUE menu allows you configure a preset total fuel value—distinct from the full value—which you can reset the fuel computer to. Finally, the ADD THRESHOLD menu allows you to configure the fuel computer to automatically detect the addition of fuel when the EMS was off. The fuel computer will check the fuel level senders at boot and prompt the pilot to add fuel when it measures an increase beyond the set threshold. The threshold is set as a percentage of the full measurable amount of fuel.

Trim Calibration

Prior to calibrating your trim sensors, ensure that you have connected them as described on page 3-15 and made the correct trim type selection for the desired GP inputs as described on page 5-17.

Enter the EMS menu by pressing any button below an EMS main page and pressing MORE > SETUP > MORE > TRIM. The TRIM CALIBRATION menu shows AILERON, ELEVATOR, and RUDDER, followed by the GP input that each is configured as (or NONE, if no GP input is configured for a given axis). Ensure that this list corresponds to the physical connections made during the setup described in the General Purpose Inputs section on page 3-15.

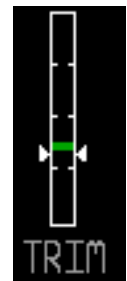

During the calibration process, the onscreen instructions will direct you to put the trim into various positions, pressing NEXT after each change. The calibration process allows you to set a takeoff trim position; this position is displayed as a green line on the trim scale info item. During the calibration process, ensure that the number shown in the VALUE field changes as you adjust the trim. If the number does not change, the trim sensor may be incorrectly wired to the EMS-D10, or incorrectly configured in the GP input selection under the SENSOR menu. At any point in the process, you may press CANCEL to end the calibration without overwriting the previous calibration results.

Once you are ready to calibrate, select the desired trim that you would like to calibrate, and press SEL ► to enter its calibration menu. Press the RANGE button to begin calibrating the range of the trim. Follow the onscreen instructions, controlling trim to the required position before

pressing NEXT. Repeat the process for the opposite position. The process will then prompt you to put the trim into takeoff position. If you do not require a takeoff indication on the given axis' trim display, you may press NONE. When you have completed the calibration, press the DONE button.

Press the TAKOFF button to calibrate the takeoff position indicator. When calibrated, a green line is displayed on the trim scales, indicating takeoff position.

View the trim display on the EMS Main or Aux page (depending on where you configured it to display) to make sure that it works as expected. You may repeat this calibration process as many times as you wish.

Flaps Calibration

Prior to calibrating your flaps sensor, ensure that you have connected it as described on page 3-15 and selected FLAP POS for the desired GP input FUNCT parameter as described on page 5-17.

Enter the EMS menu by pressing any button below an EMS main page and pressing MORE > SETUP > MORE > FLAPS. The FLAP CALIBRATION menu just shows FLAPS, followed by the GP input that each is configured as (or NONE, if no GP input is configured for a given axis). Ensure that this list corresponds to the physical connections made during the setup described in the General Purpose Inputs section on page 3-13. Press SEL▶ to enter the flaps calibration menu.



During the calibration process, ensure that the number shown in the VALUE field changes as you adjust the flaps. If the number does not change, the flaps sensor may be incorrectly wired to the EMS-D10, or incorrectly configured in the GP input selection under the SENSOR menu. At any point in the process, you may press CANCEL to end the calibration without overwriting the previous calibration results.

You must calibrate for at least 2 positions, and may calibrate for as many as 5. The calibration process first requires you to put the flaps in the 0° extended position. When you have done this, press NEXT. Next, you will calibrate for the second position. Press INC+ or DEC- to set the angle that you would like displayed for the second position. If you only wish to have 2 positions displayed, press DONE. Otherwise, press NEXT to repeat the process for the third position.

When you have completed the calibration, press DONE. View the flaps display on the EMS Main or Aux page (depending on where you configured it to display) to make sure that it works as expected. You may repeat this calibration process as many times as you wish.



Tachometer

If you have connected a tachometer source to either the RPM Left or Right inputs, set the DISPLAY parameter to ON, otherwise, set it to OFF. Next, select whether the tachometer is to the left or right of the manifold pressure display. Simply select POSITION and press SEL▶ to toggle between LEFT and RIGHT.

Select the alarm mode and the analog bar thresholds as described in Alarm and Color Threshold Configuration on page 5-2. Unlike most sensor displays, the tachometer supports a yellow band in the middle of the green band to accommodate engines which have a range of unsafe RPMs in the middle of the safe range. If you do not require this extra yellow band, simply set the LO GRN/YEL and LO YEL/GRN parameters to the same value.

Increment or decrement the PULS/REV R and L values to correspond to the number of pulses put out by your tachometer source for each engine revolution. You may select the pulses/rev for both the left and right tachometer inputs independently. If they are both p-lead inputs, these will likely be the same number. However, if you have connected different types of tachometer sources, you will likely have to input different values into these fields. If you are using a p-lead connection, the PULS/REV value will typically be set to 1/2 or 1/4 of the number of cylinders in the engine. If you find that the onscreen tachometer reads double or half what you expect, adjust the PULS/REV value until you observe the expected value. If you do not have anything hooked to one of the tachometer inputs, the PULS/REV setting for this input can be set to any value. The EMS-D10 will automatically ignore this unused input.

Next, enter your normal cruise RPM. This is used when computing Tach Time on the TIMES page. See the EMS-D10 Pilot's User Guide for more information.

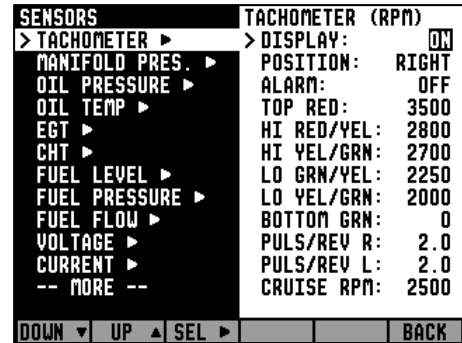

Manifold Pressure

If the manifold pressure transducer has been installed, set the DISPLAY parameter to ON, otherwise, set it to OFF. Change the SENSOR TYPE to the correct number using the sensor type table. Select the alarm mode and the analog bar thresholds as described in Alarm and Color Threshold Configuration on page 5-2. Next, select whether the tachometer is to the left or right of the manifold pressure display. Simply select POSITION and press SEL▶ to toggle between LEFT and RIGHT. You will also see a similar selection in the manifold pressure setup menu.

Select the sensor type using the sensor type table below. If you select the GRT manifold pressure sensor, you will be presented with the values AuxSF and AuxOff. You must

Sensor Type	Manifold Pressure Sensor
1	Dynon P/N 100434-000
2	GRT MAP-01 or MAP-02

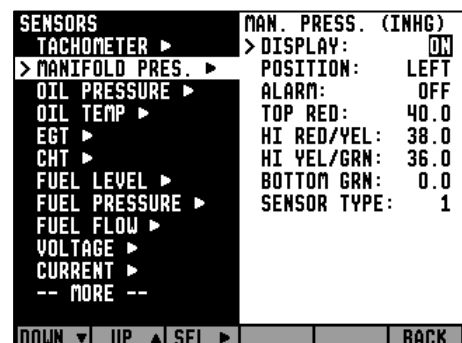



enter these values according to the ones printed on your manifold pressure sensor, provided by GRT.

Oil Pressure

Select the alarm mode and the analog bar thresholds as described in Alarm and Color Threshold Configuration on page 5-2. If the oil pressure transducer has been installed, set the DISPLAY parameter to ON, otherwise, set it to OFF. Change the SENSOR TYPE to the correct number using the sensor type table.

Sensor Type	Oil Pressure Sensor
1	Dynon P/N 100411-002 or Rotax 912 pre-installed (prior to mid-2008)
2	GRT HPS-01
3	Jabiru pre-installed
4	Rotax P/N 956413 (mid-2008 and later)

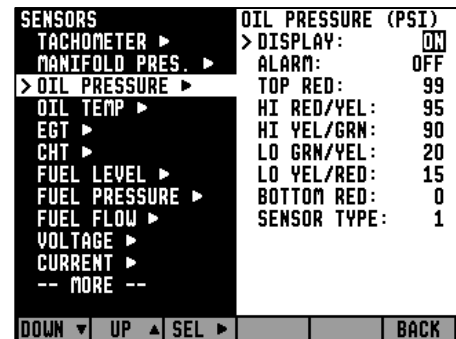

Oil Temperature

Select the alarm mode and the analog bar thresholds as described in Alarm and Color Threshold Configuration on page 5-2. If the oil temperature sensor has been installed, set the DISPLAY parameter to ON, otherwise, set it to OFF. Change the SENSOR TYPE to the correct number using the sensor type table.

Sensor Type	Oil Temp Sensor
1	Dynon P/N 100409-001
2	Dynon P/N 100409-000
3	GRT FT-LC-01
4	Rotax pre-installed
5	Jabiru pre-installed
6	Chevrolet LS7 pre-installed

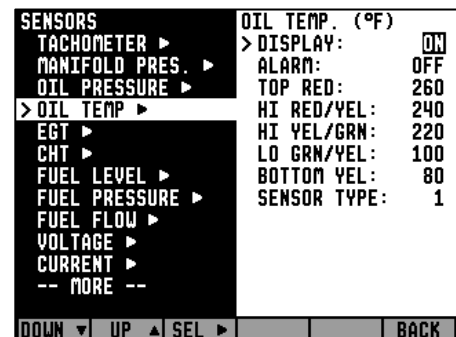

Exhaust Gas Temperature (EGT)

Select the alarm mode and the analog bar thresholds as described in Alarm and Color Threshold Configuration on page 5-2. If one or more EGT thermocouples have been installed, set the DISPLAY parameter to ON; if no EGT thermocouples are installed, set it to OFF. *There is no need to set a sensor type; any K-type thermocouple will work for this input.*

In addition to the configuration of the color thresholds, you can configure the top and bottom of the EGT/CHT analog scales independently. This allows you to show a narrower region of interest on the analog gauges to ensure easy detection of minor differences between cylinders. The TOP OF SCALE parameter defines the highest temperature displayed on the EGT analog gauge; The BOT OF SCALE parameter defines the lowest temperature displayed on the EGT analog gauge; the SCALE SECTIONS defines the number of sections into which the entire scale range is divided. Set the TOP OF SCALE, BOT OF SCALE, and SCALE SECTIONS to suit your needs.

For all SPLIT cylinder displays (2 cylinders only), you can set the SCALE SECTIONS for EGT and CHT independent of each other. For COMBD displays, EGT and CHT SCALE SECTIONS are tied together as the two sets of measurements are displayed on the same graph.

SPAN ALARMS

You may configure alarms based on the overall temperature span between the hottest and coolest cylinders' EGTs. The span alarm configuration is located on the second page; press DOWN ▼ from the bottom of page 1. First, press SEL ► to toggle the DETECT setting to ON. Like other alarms, you can cycle ALARM through SELF-CLEAR, LATCHING, and OFF. See Alarm and Color Threshold Configuration on page 5-2 for definitions of those functions. Next, configure the MAX SPAN (the maximum temperature difference between hottest and coolest cylinders, in the units shown at the top of the menu) during non-leaning conditions. Next, configure the maximum span while leaning in the WHEN LEANING section. If you do not wish to have a different span alarm value while leaning, you must still configure this value to equal that of MAX SPAN. When the difference between your hottest and coldest cylinders' EGTs is greater than the MAX SPAN value (or WHEN LEANING value, when leaning), a span alarm is triggered. When this occurs, those two EGT values will alternate between their actual value and a SPN alert. If you have configured the ALARM setting to either SELF-CLEAR or LATCHING, the SPN alarm will be red and will be accompanied by an alarm bar. If you have configured ALARM to be OFF, the SPN alarm will be yellow.

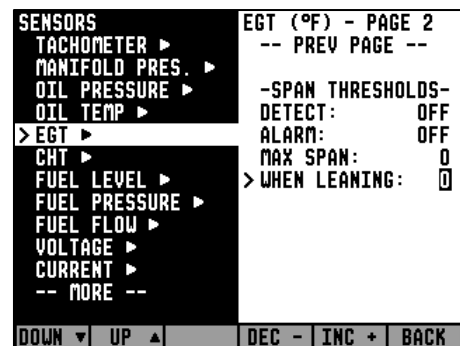
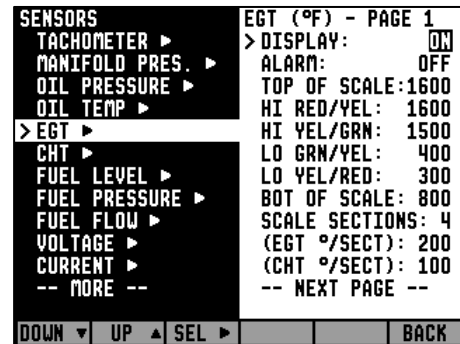

Cylinder Head Temperature (CHT)

Select the alarm mode and the analog bar thresholds as described in Alarm and Color Threshold Configuration on page 5-2. If one or more CHT sensors have been installed, set the DISPLAY parameter to ON; if no CHT sensors are installed, set it to OFF. If you are using J-type thermocouples, you are finished with the CHT configuration; there is no need to configure a sensor type. If you have a Rotax and are using resistive CHT sensors, refer to the General Purpose Inputs section on page 5-16 to configure the instrument to recognize your sensors.

SENSORS		CHT (°F) - PAGE 1	
TACHOMETER ▶		> DISPLAY:	ON
MANIFOLD PRES. ▶		ALARM:	OFF
OIL PRESSURE ▶		TOP OF SCALE:	600
OIL TEMP ▶		HI RED/YEL:	500
EGT ▶		HI YEL/GRN:	450
> CHT ▶		LO GRN/YEL:	200
FUEL LEVEL ▶		LO YEL/RED:	150
FUEL PRESSURE ▶		BOT OF SCALE:	200
FUEL FLOW ▶		SCALE SECTIONS:	4
VOLTAGE ▶		(CHT %/SECT):	100
CURRENT ▶		(EGT %/SECT):	200
-- MORE --		-- NEXT PAGE --	
DOWN ▼	UP ▲	SEL ▶	BACK

In addition to the configuration of the color thresholds, you can configure the top and bottom of the EGT/CHT analog scales independently. This allows you to show a narrower region of interest on the analog gauges to ensure easy detection of minor differences between cylinders. The TOP OF SCALE parameter defines the highest temperature displayed on the EGT analog gauge; The BOT OF SCALE parameter defines the lowest temperature displayed on the EGT analog gauge; the SCALE SECTIONS defines the number of sections into which the entire scale range is divided. Set the TOP OF SCALE, BOT OF SCALE, and SCALE SECTIONS to suit your needs. For all SPLIT cylinder displays (2 cylinders only), you can set the SCALE SECTIONS for EGT and CHT independent of each other. For COMBD displays, EGT and CHT SCALE SECTIONS are tied together as the two sets of measurements are displayed on the same graph.

SPAN ALARMS

You may configure alarms based on the overall temperature span between the hottest and coolest cylinders' CHTs. The span alarm configuration is located on the second page; press DOWN ▼ from the bottom of page 1. First, press SEL ▶ to toggle the DETECT setting to ON. Like other alarms, you can cycle ALARM through SELF-CLEAR, LATCHING, and OFF. See Alarm and Color Threshold Configuration on page 5-2 for definitions of those functions. Next, configure the MAX SPAN (the maximum temperature difference between hottest and coolest cylinders, in the units shown at the top of the menu) during non-leaning conditions. Next, configure the maximum span while leaning in the WHEN LEANING section. If you do not wish to have a different span alarm value while leaning, you must still configure this value to equal that of MAX SPAN. When the difference between your hottest and coldest cylinders' CHTs is greater than the MAX SPAN value (or WHEN LEANING value, when leaning), a span alarm is triggered. When this occurs, those two CHT values will alternate between their actual value and a SPN alert. If you have configured the ALARM setting to either SELF-CLEAR or LATCHING, the SPN alarm will be red and will be accompanied by an alarm bar. If you have configured ALARM to be OFF, the SPN alarm will be yellow.

SENSORS		CHT (°F) - PAGE 2	
TACHOMETER ▶		-- PREV PAGE --	
MANIFOLD PRES. ▶		-SPAN THRESHOLDS-	
OIL PRESSURE ▶		DETECT:	OFF
OIL TEMP ▶		ALARM:	OFF
EGT ▶		MAX SPAN:	0
> CHT ▶		WHEN LEANING:	0
FUEL LEVEL ▶		-SHOCK COOLING-	
FUEL PRESSURE ▶		DETECT:	OFF
FUEL FLOW ▶		ALARM:	OFF
VOLTAGE ▶		> MAX %/MIN:	0
CURRENT ▶			
-- MORE --			
DOWN ▼	UP ▲	DEC -	INC +
			BACK



SHOCK COOLING ALARMS

You may configure alarms that trigger on the rate of cylinder head cooling. Press DOWN ▼ to select DETECT, below SHOCK COOLING. Then, press SEL ► to toggle the DETECT setting to ON. Like other alarms, you can cycle ALARM through SELF-CLEAR, LATCHING, and OFF. See Alarm and Color Threshold Configuration on page 5-2 for definitions of those functions. Next, configure the MAX °/MIN (maximum degrees of cooling per minute) parameter to the desired value. When any CHT's rate of cooling exceeds this value, a shock cooling alarm is triggered. When this occurs, the CHT(s) exceeding the defined maximum cooling rate will alternate between their actual value and a SHK alert. If you have configured the ALARM setting to either SELF-CLEAR or LATCHING, the SHK alarm will be red and will be accompanied by an alarm bar. If you have configured ALARM to be OFF, the SHK alarm will be yellow.



Fuel Level

If one or more fuel level transducers have been installed, set the DISPLAY parameter to ON; if no fuel level sensors are installed, set it to OFF. Select the alarm mode and the analog bar thresholds as described in Alarm and Color Threshold Configuration on page 5-2. You may select the on-screen names for the Tank 1 and Tank 2 inputs. You may choose from LEFT, MAIN, and TNK1 for Tank 1. You may choose from RIGHT, AUX, and TNK2 for Tank 2. Change the SENSOR TYPE to the correct number using the sensor type table.

Sensor Type	Fuel Level Sensor
1	Resistive float-type sender
2	Capacitive sender(voltage output)

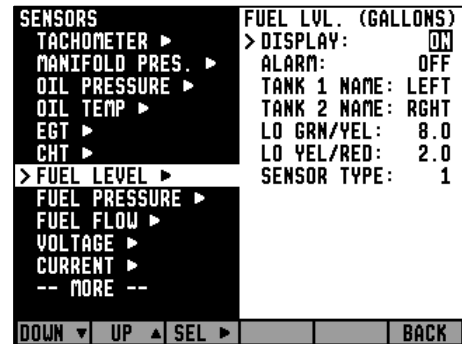

Fuel Pressure

If the fuel pressure transducer has been installed, set the DISPLAY parameter to ON, otherwise, set it to OFF. Select the alarm mode and the analog bar thresholds as described in Alarm and Color Threshold Configuration on page 5-2. Change the SENSOR TYPE to the correct number using the sensor type table.

Sensor Type	Fuel Pressure Sensor
1	Dynon P/N 100411-000 (carbureted)
2	Dynon P/N 100411-001 (injected)
3	GRT LPS-02 (remove the external pull-up resistor)

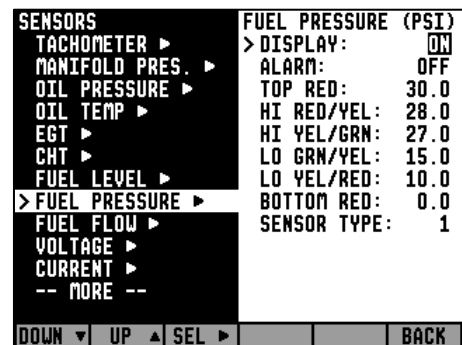

Fuel Flow

If the fuel flow transducer has been installed, set the DISPLAY parameter to either TEXT or DIAL. When set to TEXT, the fuel flow indication is displayed as a numerical value above a graphical fuel pressure dial. When set to DIAL, the opposite is true. Note that changing this value toggles the equivalent value in the FUEL PRESSURE menu. Fuel flow can also be displayed as an info bar, as described in the EMS-D10 Pilot's User Guide > Global Configuration Settings > Info Item Configuration section.

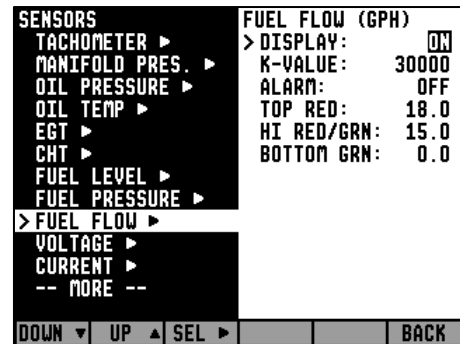

Select the alarm mode and the analog bar thresholds as described in Alarm and Color Threshold Configuration on page 5-2. Next, find the K-value associated with your fuel flow transducer. If you have the **Floscan 201B (Dynon P/N 100403-001)**, this number can be found on the tag that came with the transducer. **The K-value for your transducer is 10 times the number shown after the dash.** So, if your transducer had the tag shown at right attached to it, you would enter a K-value of 29590 in the K-VALUE section of the Fuel Flow configuration menu. If you have lost your tag, a starting K-value of 30000 will be close enough to begin using the function.

If you have the **EI FT-60 "Red Cube" (Dynon P/N 100403-003)**, enter a starting K-VALUE of **68000**.

Over time, you may notice that the instrument's computation of gallons or liters remaining (based on fuel flow) is either high or low. This is a result of many factors, including individual installation. To correct for this, follow this procedure:

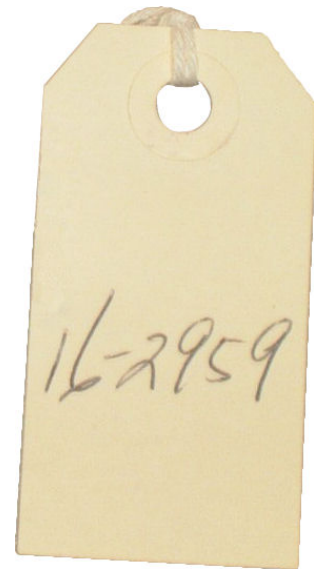

Over several fill-ups keep a running total of the amount of fuel added. Keep a running total of the GALS (or LTRS) USED parameter over this same time span.

Perform the following calculation: $\frac{\text{FuelUsed}(\text{computed})}{\text{FuelFilled}(\text{actual})}$. You should obtain a number that is

close to 1. We'll call this number, KFactorRatio.

Now perform this calculation: $\text{CurrentKFactor} * \text{KFactorRatio}$. Enter this number as your new K-Factor.

Observe the results over your next tank for accuracy. Repeat the above if necessary.

The general rule of thumb: if your GALS (or LTRS) USED reads higher than you expect, *increase* the K-factor; if it reads lower than you expect, *decrease* the K-factor.

If the GLOBAL > ENGINE TYPE setting is set to ROTAX, a return flow (RETRN FLOW) setting is available in this menu. This function is generally used only by Original Equipment Manufacturers (OEMs).



Voltage

The voltmeter info item reports the voltage that the EMS-D10 reads on its Master Power input (pin 1 on the EMS 37-pin connector). Because of this, there is no sensor to install or configure. Simply, select the alarm mode and the analog bar thresholds as described in Alarm and Color Threshold Configuration on page 5-2. Configure the voltmeter info bar to display in the desired location(s), as described in the EMS-D10 Pilot's User Guide > Global Configuration Settings > Info Item Configuration section.

Current

If a current sensor has been installed, set the DISPLAY parameter to ON, otherwise, set it to OFF. First, select whether your ammeter will be showing positive and negative currents (-60A TO 60A; used for Location A) or only positive currents (0A TO 60A; used for Locations B and C). This will depend on your installation as mentioned in the Ammeter Shunt installation section on page 3-12. Select the alarm mode and the analog bar thresholds as described in Alarm and Color Threshold Configuration on page 5-2. Change the SENSOR TYPE to the correct number using the sensor type table. Configure the ammeter info bar to display in the desired location(s), as described in the EMS-D10 Pilot's User Guide > Global Configuration Settings > Info Item Configuration section.

Sensor Type	Ammeter Sensor
1	Dynon P/N 100412-000
2	GRT CS-01

SENSORS	CURRENT (AMPS)
TACHOMETER ▶	> TYPE: -60A TO 60A
MANIFOLD PRES. ▶	ALARM: OFF
OIL PRESSURE ▶	TOP RED: +20.0
OIL TEMP ▶	HI RED/YEL: +16.0
EGT ▶	HI YEL/GRN: +15.0
CHT ▶	LO GRN/YEL: -10.0
FUEL LEVEL ▶	LO YEL/RED: -14.0
FUEL PRESSURE ▶	BOTTOM RED: -15.0
FUEL FLOW ▶	SENSOR TYPE 1
VOLTAGE ▶	DISPLAYED: INFO 3
> CURRENT ▶	
-- MORE --	
DOWN ▼ UP ▲ SEL ▶	BACK

If you are using the GRT CS-01 Hall effect sensor, you may need to set the zero-point of the sensor. After you have selected a SENSOR TYPE of "2," the OFFSET parameter will be displayed. Adjust the OFFSET (in increments of 1 amp) until the current displayed on the EMS Main page screen is correct at a known current.



General Purpose Inputs

In each of the 3 EMS GP INPUT submenus, you must select the function corresponding to the sensor that is installed for the respective GP connection. Ensure that you have configured your info items on the main and aux pages to display the desired GP inputs. Note that each GP menu will have help text, reading “DISPLAYED: INFO #” for each info item position where the given GP parameter is displayed. If the given info item is not configured to display anywhere, no text will be shown. Configure the info item (bar, text, or flaps/trim) for each GP input to display in the desired location(s), as described in the EMS-D10 Pilot’s User Guide > Global Configuration Settings > Info Item Configuration section.

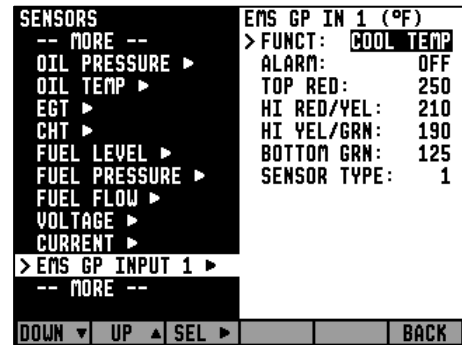

HS34 The General Purpose Inputs listed below the HS34 INPUTS section, (HS34 GP INPUT 1, 2, 3) can only be used with an HS34 installed and configured

! We recommend that you set the **FUNCT** for all unused GP inputs to **UNUSED**.

ROTAX CHT

Select GP INPUT 1 and press SEL to change the FUNCT parameter to ROTAX CHT L. Back out and select GP INPUT 2 and press SEL to change the FUNCT parameter to ROTAX CHT R. Refer to the Cylinder Head Temperature (CHT) setup section on page 5-11 for information about changing the various CHT-related parameters.

RESISTIVE FUEL LEVEL

Under the desired GP input number, set FUNCT to FUEL LVL 3 or FUEL LVL 4 (if FUEL LVL 3 has already been chosen on a different GP input). All fuel level inputs use the same alarm settings. Configure these as described in the Alarm and Color Threshold Configuration on page 5-2.

CARBURETOR TEMPERATURE

Under the desired GP input number, set FUNCT to CARB TEMP. Select the analog bar thresholds as described in the Alarm and Color Threshold Configuration on page 5-2. Set the SENSOR TYPE to the correct number using the sensor type table.

Sensor Type	Carburetor Temp Sensor
1	Dynon P/N 100413-000 (with black wires)
2	GRT CARB-01
3	Dynon P/N 100468-000 (with white/black wires)

COOLANT TEMPERATURE

Under the desired GP input number, set FUNCT to COOL TEMP. Select the analog bar thresholds as described in the Alarm and Color Threshold Configuration on page 5-2. Set the SENSOR TYPE to the correct number using the sensor type table.

Sensor Type	Coolant Temp Sensor
1	Dynon P/N 100409-001
2	Chevrolet LS7 pre-installed
3	Dynon P/N 100409-000
4	Rotax 801-10-1

COOLANT PRESSURE

Under the desired GP input number, set FUNCT to COOL TEMP. Select the analog bar thresholds as described in the Alarm and Color Threshold Configuration on page 5-2. Set the SENSOR TYPE to the correct number using the sensor type table.

Sensor Type	Coolant Pressure Sensor
1	Dynon P/N 100411-000

OUTSIDE AIR TEMPERATURE SENSOR

Under the desired GP input number, set FUNCT to OAT. Select the analog bar thresholds as described in the Alarm and Color Threshold Configuration on page 5-2. Set the SENSOR TYPE to the correct number using the sensor type table.

Sensor Type	OAT Sensor
1	Dynon P/N 100433-000 (2-wire) Dynon P/N 100433-001 (3-wire, when installed as described on page 3-13)
2	GRT OAT-01

If you have installed a Dynon Avionics OAT to a General Purpose Input enter the EMS setup menu by pressing SETUP > SENSOR > EMS GP INPUT. Set the desired GP Input to OAT and select sensor type 1.



Do not set the sensor type in the EFIS > SETUP > OAT menu on any DSAB-connect EFIS instruments. Ensure that the INSTALLED value in the EFIS OAT menu is set to N.

AILERON TRIM

Under the desired GP input number, set FUNCT to TRIM AILRN. There are no alarm thresholds or any other setting required for aileron trim.

ELEVATOR TRIM

Under the desired GP input number, set FUNCT to TRIM ELEV. There are no alarm thresholds or any other setting required for elevator trim.

RUDDER TRIM

Under the desired GP input number, set FUNCT to TRIM RUDR. There are no alarm thresholds or any other setting required for rudder trim.

FLAP POSITION

Under the desired GP input number, set FUNCT to FLAP POS. There are no alarm thresholds or any other setting required for flap position.



GENERAL PURPOSE TEMPERATURE

Under the desired GP input number, set FUNCT to GP TEMP. Select the analog bar thresholds as described in the Alarm and Color Threshold Configuration on page 5-2. Set the SENSOR TYPE to the correct number using the sensor type table.

Press DOWN ▼ to select the LABEL 1 field. The first character of the 4-character name is highlighted. Press INC+ or DEC- to cycle through the numbers and letters for the first character. When you have selected the desired letter, press SEL ► to move to the next character. Repeat this for each of the characters in the contact name field. If desired, repeat this for LABEL 2. If you leave LABEL 2 with its default “----” value, the temperature units are displayed beneath the temperature bar’s label; otherwise, the value of LABEL 2 is displayed.

Sensor Type	GP Temp Sensor
1	Dynon P/N 100433-000 (2-wire) Dynon P/N 100433-001 (3-wire, when installed as described on page 3-13)
2	GRT OAT-01

Contacts

Note that while contacts are shown below the HS34 INPUTS section, they are not available until you purchase and connect an HS34 expansion module. Ensure you are configuring in either of the two EMS CONTACT menus.

To access the CONTACTS configuration page, select EMS > SETUP > SENSOR > EMS CONTACT 1 or CONTACT 2.

Select the alarm mode as described in the Alarm and Color Threshold Configuration on page 5-2. Contacts can only be configured as an INFO ITEM. Configure the contacts info item to display in the desired location(s), as described in the EMS-D10 Pilot's User Guide > Global Configuration Settings > Info Item Configuration section.

Press DOWN ▼ to select the NAME field that you want to appear for CONTACT (1 or 2). The first character of the 4-character name is highlighted. Press INC+ or DEC- to cycle through the numbers and letters for the first character. When you have selected the desired letter, press SEL ► to move to the next character. Repeat this for each of the characters in the contact name field.

Press DOWN ▼ to select CLSD LABEL. The label you enter here will be shown when CONTACT (1 or 2) is closed (connected to ground). Select CLSD COLOR and press SEL ► until the desired color for a closed contact is displayed. Repeat these two steps for OPEN LABEL (label shown when contact is disconnected from ground) and OPEN COLOR.

Contact alarm triggering is based on the color selected in the COLOR field for either of the states. If you have selected a SELF-CLEAR or LATCHING alarm for a contact and it enters a state selected to be RED, the EMS will display the alarm bar and the contact label will blink onscreen.

HS34 The Contact Inputs listed below the HS34 INPUTS section, (HS34 CONTACT 1, 2, 3, 4) can only be used with an HS34 installed and configured.





General Purpose Thermocouple

Select the alarm mode as described in the Alarm and Color Threshold Configuration section on page 5-2.

Configure the GP thermocouple info bar to display in the desired location(s), as described in the EMS-D10 Pilot's User Guide > Global Configuration Settings > Info Item Configuration section.

Sensor Type	GP Temp Sensor
J	J Type Thermocouple
K	K Type Thermocouple

After configuring alarms, press DOWN ▼ to select the LABEL 1 field. The first character of the 4-character name is highlighted. Press INC+ or DEC- to cycle through the numbers and letters for the first character. When you have selected the desired letter, press SEL ► to move to the next character. Repeat this for each of the characters in the contact name field. If desired, repeat this for LABEL 2. If you leave LABEL 2 with its default “----” value, the temperature units are displayed beneath the temperature bar's label; otherwise, the value of LABEL 2 is displayed. Set the SENSOR TYPE to J or K, depending on the thermocouple type used.

6. DSAB CONFIGURATION

This section introduces some concepts that are central to understanding and configuring a network of DSAB-capable Dynon products. It then takes you through a series of simple steps to configure your network, enabling data sharing and HS34 functionality. Do not proceed with DSAB configuration until you perform all installation, calibration, and configuration steps for each instrument with a display. Display-less instruments – such as the HS34 – cannot be fully configured until DSAB is active, although their physical and electrical installation should be complete.

You must configure a DSAB network from an EFIS-based instrument; however, status information and brightness configuration are available from EMS-only instruments.

Network Concepts

A few concepts must be understood before configuring a DSAB-connected system. The most important is that of Dynon products as **providers** of functions to the network. These various functions are called **roles**. Some products, such as the HS34, only have one role on the network; other products can provide multiple roles at a time. When a device has been assigned to provide a role to the network, no other device on the network can provide that role at the same time.

Assignable roles by product	EFIS-D10A/ EFIS-D100	EMS-D10/ EMS-D120	FlightDEK- D180	HS34	SV32/42/52	AP74
Bus Master	X		X			
EFIS	X		X			
EMS		X	X			
OAT	X	X	X			
Compass	X		X			
HS34				X		
Autopilot	X		X			
AP Control Panel						X
AP Roll/Pitch Servo					X	

The table at right lists all available roles and the products which they can be assigned to. Again, each role can be assigned to no more than one device on the network.

Another important concept is that of the **Bus Master**. A DSAB-connected network must have at least one EFIS-based product (EFIS-D10A, EFIS-D100, or FlightDEK-D180), and only an EFIS-based product can be assigned the Bus Master role. The Bus Master is the instrument which manages communication on the network. Additionally, if Autopilot servos are installed, the Bus Master is the Autopilot. While the Autopilot can be controlled from slave devices, if the Bus Master is not present, the Autopilot will not function. If the Bus Master is turned off or fails, all data sharing ceases, causing units to display internally-derived data only. When you first perform DSAB network configuration on an EFIS-based instrument, that device is automatically assigned



the Bus Master role. Perform DSAB configuration on your primary EFIS-based instrument, as the Bus Master is also the default provider for both the EFIS and Compass roles.

Example Networks

The following two diagrams present example DSAB-connected networks. These examples illustrate and expand upon some of the concepts discussed above. The first diagram depicts a system without an HS34 connected, demonstrating where NAV and GPS devices should be connected. The second diagram depicts a system with an HS34 connected, demonstrating that all NAV and GPS devices must be connected to the HS34. Both diagrams discuss what devices can be assigned various roles and what happens when DSAB fails.

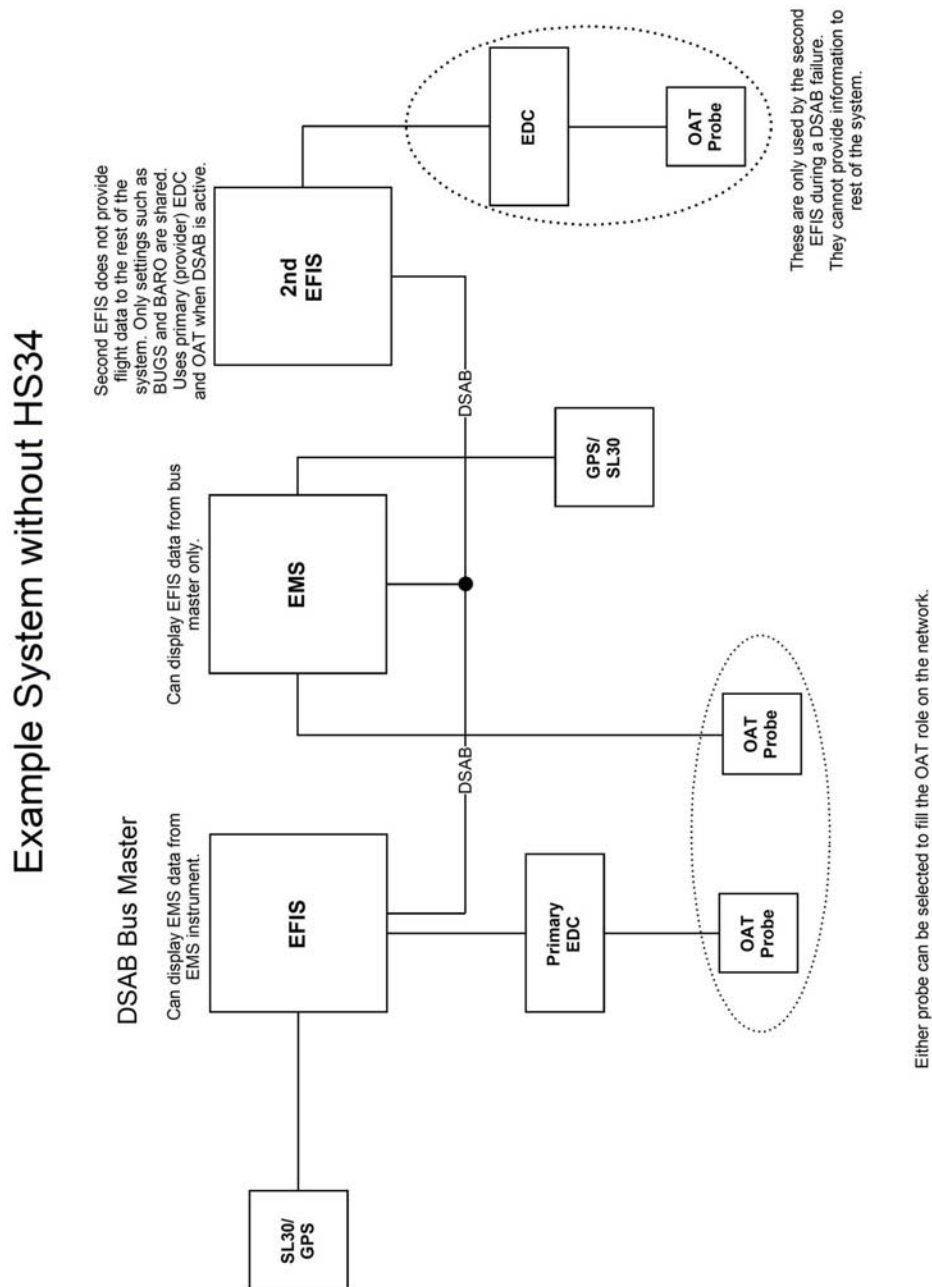

Example System with HS34

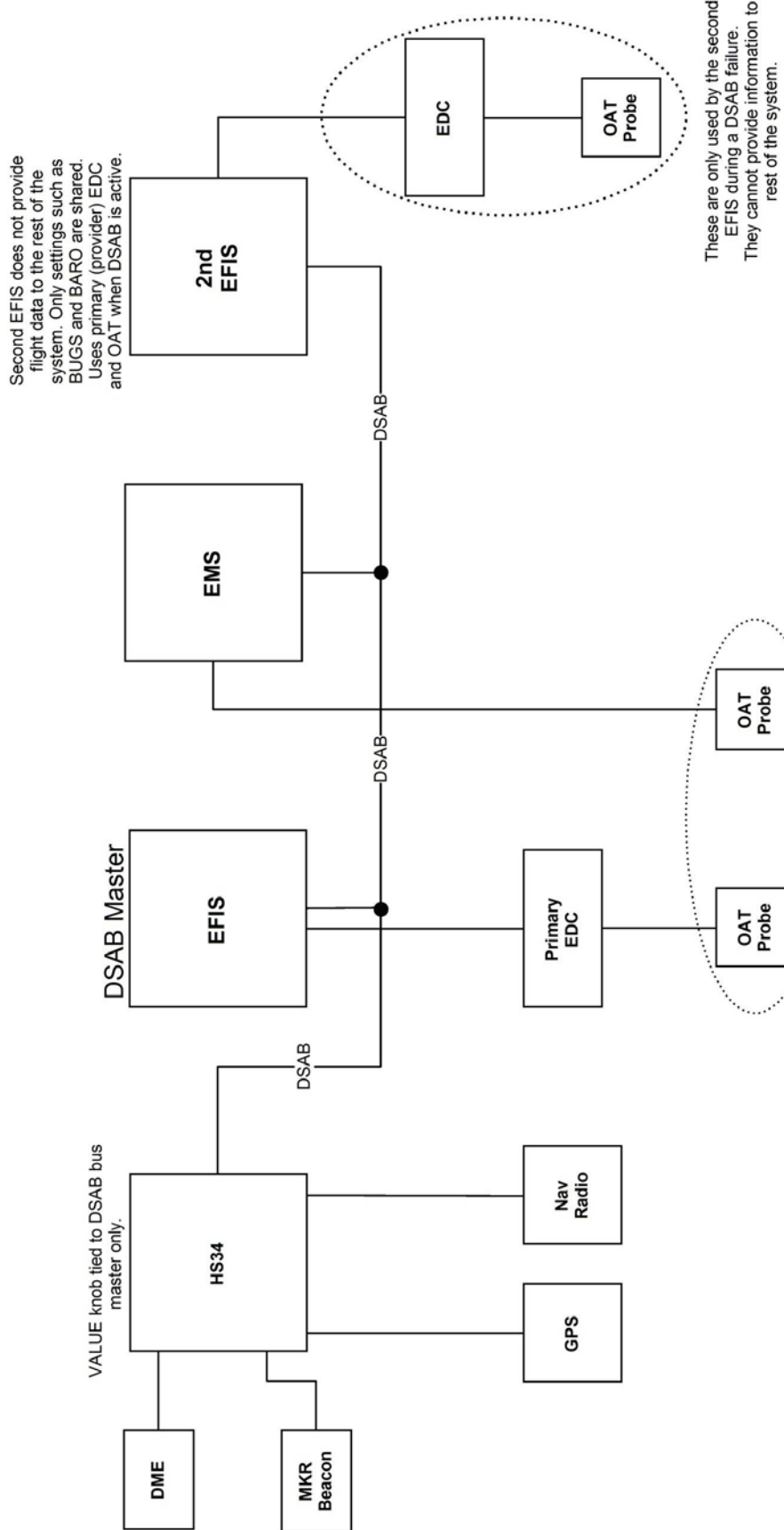

Either probe can be selected to fill the OAT role on the network.

Initial Setup

Please refer to your EFIS-based product's Installation Guide for detailed information on setting up and configuring your DSAB network.

Network Status

The STATUS submenu displays information on all configured devices, their serial numbers, their roles on the network, and their status.

The first line indicates how many devices are configured on the network. This number is independent of the number of devices actually currently turned on and communicating. It simply reports how many instruments were present during the most recent execution of DSAB configuration.

The next several lines indicate the available roles that the selected instrument can provide. A "*" is placed next to the roles that the instrument is currently providing to the network. If any of those roles cannot be detected (e.g., the EFIS's compass has been disconnected), a "?" is displayed next to that role. Any given instrument in the list can have one of the following STATUS messages:

DSAB NETWORK		DSAB STATUS	
> STATUS ►		2 NETWORK DEVICES	
CONFIGURATION ►		> EFIS-0100 01082	
*: ?:		CAN PROVIDE:	
*: ?:		* BUS MASTER	
*: ?:		* EFIS	
*: ?:		* COMPASS	
*: ?:		STATUS: ACTIVE	
*: ?:		-- MORE --	
DOWN ▼	UP ▲	IDENT	BACK

- **ACTIVE** – The device is communicating normally on DSAB.
- **STANDALONE** – During configuration as Bus Master, no other DSAB devices were found.
- **UPGRADE REQ** – Device has a different firmware version than the Bus Master and thus cannot communicate on DSAB.
- **OFFLINE** – The specified device cannot communicate on DSAB or is powered off.
- **PEERS LOST** – (Only appears on Bus Master) – The Bus Master was configured with other DSAB devices present; however, all of them are currently offline.

If an instrument's STATUS field displays UPGRADE REQ, PEERS LOST, or OFFLINE, all of its provided roles are listed as not detected.

The selected instrument's serial number is displayed, assisting in identification. Additionally, pressing IDENT causes the selected instrument's display to display a black screen with the text DSAB IDENT shown. If the instrument you wish to identify is the one which you are currently interacting with, the line changes to read THIS UNIT.

Press DOWN ▼ or UP ▲ to scroll through each of the other instruments configured in your network.

7. APPENDIX

This appendix contains additional information pertaining to the installation of the EMS-D10. You will find here the optional capacitance fuel level converter guide, and a table of weights, specifications.

Appendix A: Capacitance-to-Voltage Converter Installation

Dynon Avionics' capacitance-to-voltage converter is suitable for general use with most capacitive plate fuel level sensors. It accepts an input via a female BNC and outputs a dc voltage signal that can be read by the EMS-D10. It requires 10 Vdc to 15 Vdc for power and draws minimal current. We recommend that you connect the capacitance-to-voltage converter to the EMS for power as shown in the table below, but it will also work properly when connected directly to standard 12 volt aircraft power. If your aircraft runs on 28 volt power, you *must* connect the capacitance-to-voltage converter to the EMS for its power source. Voltage inputs higher than 15 volts will damage the device.



GENERAL INSTALLATION RECOMMENDATIONS

Connect the female BNC to the male BNC provided with your capacitive fuel level sensor. Connect the wires as shown in the table to your EMS-D10. If you need to extend the wire beyond the supplied length, we recommend avionics grade 22 AWG wire with Tefzel® type insulation.

Refer to the 37-Pin Female EMS Harness section on page 2-3 for EMS pin out information when connecting this product to your EMS-D10.

Wire	EMS DB37 Pin#	Function
Black	5, 16, or 17	Ground
White	20 (fuel level 1) 21 (fuel level 2)	Capacitance converter output to EMS fuel level input (0 Vdc to 5 Vdc)
Red	15	12 Vdc Power (normally used for fuel flow)

You must configure the fuel level sensor type on your EMS-D10 to capacitive sender before calibrating this product. Refer to the Fuel Level configuration section on page 5-11 for fuel level sender type configuration and page 5-5 for fuel level sender calibration.



Once the system is calibrated for a certain type fuel, only that fuel may be used and the aircraft should be placarded for such. For example, ethanol has a dielectric constant much different than 100LL or Auto Fuel. If calibrated for 100LL, then by using Auto 10% Ethanol in the tanks the indications could be off by 50%.



Appendix B: Troubleshooting

The following table provides a list of potential issues that the EMS-D10 may experience. The symptom is given on the left side while the probable solution is listed at the right. You may also post about your issue at forum.dynonavionics.com, where we and other active users may be able to assist you.

Problem	Solution
EMS-D10 displays continuous or blinking blue screen	Ensure that your power supply is capable of supplying at least 2 amps and that it is at least 10 volts. If, after verifying that you have met these two conditions the unit does not operate normally, it is necessary to contact Dynon Avionics.
EMS-D10 screen stays black when power is applied	Verify Master Power is connected. Verify Master Power is above 10 volts.
Clock setting is lost	Verify Keep Alive power is supplied to unit at all times.
Cannot make connection with PC	Verify wiring is correct. Verify no other programs using the COM port are running on the PC. Verify latest version of The Dynon Product Support Program is being used.

INSTRUCTIONS FOR RETURN

If none of the above sections have helped resolve an ongoing issue with your EMS-D10, please call Dynon Avionics at 425-402-0433 to discuss the issue with Technical Support. If, after troubleshooting with a Dynon representative, the issue cannot be resolved, we will provide you with an RMA number to use when shipping the EMS-D10 to us. If your unit is still under warranty, the repairs will be performed and the EMS-D10 will be returned promptly. If your warranty has expired, the Dynon representative will make arrangements with you and make you fully aware of the costs before proceeding with the repair.

While Dynon Avionics makes every effort to save and restore your unit's settings and calibrations, we cannot guarantee that this will happen. When you receive your EMS-D10, it may have newer firmware installed on it than it did when you sent it in. Check downloads.dynonavionics.com for information on what's new.

Appendix C: Weights

Adding any new instrument to an aircraft requires the installer to be aware of its weight and how that affects the overall weight and balance of the plane. The following are the weights of the EMS-D10 and associated Dynon-supplied sensors

EMS-D10	1 lb 4 oz (0.567 kg)
Manifold pressure Sender	3 oz (0.09 kg)
Oil pressure sender.....	4 oz (0.11 kg)
Fuel pressure sender.....	4 oz (0.11 kg)
Oil temperature sender.....	2 oz (0.06 kg)
Flush mount bracket.....	2 oz (0.06 kg)
37-pin wiring harness.....	13 oz (0.37 kg)
25-pin thermocouple wiring harness.....	11 oz (0.31 kg)
EGT probe.....	1.3 oz (0.04 kg) (times # of probes)
CHT probe	1.3 oz (0.04 kg) (times # of probes)
OAT sender.....	3 oz (0.09 kg)
Fuel flow sender.....	4 oz (0.11 kg)
Carburetor temperature sender.....	2 oz (0.06 kg)
Ammeter shunt.....	5 oz (0.14 kg)



Appendix D: EMS-D10 Specifications

Mechanical	Fits into standard 3 1/8" panel hole Optional flush mount bracket available
Operating Temperature	-22° to 122° F (-30° to 50° C)
Power	Voltage: 10 - 30 Vdc Power: 8 watts typical; 10 watts maximum
Connections	Wiring: DB25 female & DB37 male connectors
Screen	Type: AMLCD, TFT (Thin Film Transistor) Backlight: 450 nits Size: 3.8" diagonal (96 mm) Resolution: 320 x 240 color pixels
Sensor Inputs	6 - EGT (Type K Thermocouple) 6 - CHT (Type J Thermocouple) 2 - Fuel Level (Resistive or Capacitance with 5 volt output) 2 - RPM (P-lead or pickup) 2 - Contacts 1 - Manifold Pressure (voltage) 1 - Oil Temperature (Resistive) 1 - Oil Pressure (Resistive) 1 - Fuel Pressure (Resistive) 1 - Fuel Flow (Frequency) 1 - Current (Shunt) 1 - Voltage (from supply power) 1 - Turbine Inlet Temperature (Type K Thermocouple) 3 - General Purpose (Either resistive or voltage for OAT, Fuel Tanks 3&4, Coolant Temp, Coolant Press, Carburetor Temp)
Inputs/Outputs	1 - Alarm Light Contact 1 - Audio Alarm 1 - RS-232 bidirectional PC communication 1 - RS-232 data input (GPS, SL30, etc.) 1 - Dynon Smart Avionics Bus (DSAB) differential