



SkyView SE
SkyView Classic
SkyView Touch
SkyView HDX

Third-Party Device Connection and
Configuration

Reference Guide

104215-000

Rev-BRev C

4/3/20234/4/2023

Copyright © 20232024 by Dynon Avionics, Inc.

Dynon Avionics grants third parties' permission to print this document

Contact Information

Dynon Avionics, Inc.
19825 141st Place NE
Woodinville, WA 98072

Technical Support

Phone: +1 (425) 224-6736, 8:00 AM – 5:00 PM (Pacific Time) Monday – Friday
Email: support@dynon.com

Sales

Phone: +1 (425) 650-1269, 8:00 AM – 5:00 PM (Pacific Time) Monday – Friday
Email: sales@dynon.com

Find Us on the Web

dynon.com – Dynon homepage
dynon.com/docs – Product documentation
dynon.com/download – Software updates for products
dynon.com/support – Support resources
dynon.com/register – Register your Dynon Avionics product
shop.dynon.com – Dynon’s *secure* online store

Stay in Touch

dynon.com/newsletter – Sign up to receive Dynon’s newsletter
forum.flydynon.com – Dynon-hosted forum for customers and pilots
preflight.dynon.com – Dynon’s blog
facebook.com/dynonavionics
instagram.com/dynonavionics
twitter.com/dynon

Videos and Training

youtube.com/DynonAvionics – Training, events, and other videos on YouTube

Copyright

©20232024 Dynon Avionics, Inc. All rights reserved. No part of this manual may be reproduced, copied, transmitted, disseminated, or stored in any storage medium, for any purpose without the express written permission of Dynon Avionics. Dynon Avionics hereby grants permission to download a single copy of this manual and of any revision to this manual onto a hard drive or other electronic storage medium to be viewed for personal use, provided that such electronic or printed copy of this manual or revision must contain the complete text of this copyright notice and provided further that any unauthorized commercial distribution of this manual or any revision hereto is strictly prohibited.

Information in this document is subject to change without notice. Dynon Avionics reserves the right to change or improve its products and to make changes in the content without obligation to notify any person or organization of such changes. Visit the Dynon Avionics website (dynon.com) for current updates and supplemental information concerning the use and operation of this and other Dynon Avionics products.

Revision History

REV	DATE	APPROVED	DESCRIPTION OF CHANGE
AC	7/5/2022 4/2024	ECO 342230391142	<ul style="list-style-type: none">• Initial ReleaseCorrected typos in Section 2.7.• Added Section 2.8.
B	4/3/2023	ECO 383895	<ul style="list-style-type: none">• Fixed various typos throughout document.• Re-structured Section 2 to provide specific configurations for devices.• Added Apollo CNX80 to Section 2.5 and updated settings.• Revised Figure 7.• Added correct Pin #s in Section 3.3.5.
A	7/5/2022	ECO 342230	Initial Release

Table of Contents

1	Introduction	1
1.1	Using this Manual	1
1.2	Document Iconography	1
1.3	Reference Documents.....	1
2	Connecting and Configuring ARINC-429 GPS Navigators	2
2.1	SV-ARINC-429 Related Settings.....	2
2.2	Generic Electrical Connections.....	3
2.3	Garmin GNS 4XX/5XX Series	4
2.4	Garmin GTN 6XX/7XX Series.....	6
2.5	Garmin GNS 480 and Apollo CNX80.....	8
2.6	Garmin GNC Series.....	10
2.7	Garmin GPS 175 / GNC 355	12
2.8	Garmin GNX 375	15
2.9	Avidyne IFD 4XX/5XX Series	17
3	Connecting and Configuring Serial Devices	20
3.1	General Serial Connection Procedure	22
3.2	Traffic Devices.....	23
3.3	NAV / COM Devices	28
3.4	Portable GPS Devices.....	35
3.5	Emergency Location Transmitter (ELT) Devices	37
3.6	Vertical Power VP-X.....	38
4	Appendix 1: NMEA OUT Data Formats	43

1 Introduction

This document is a supplemental reference to the *Skyview System Installation Guide* document.

1.1 Using this Manual

To reduce paper, Dynon does not provide a printed version of this manual. However, Dynon grants permission to third parties to print this manual, as necessary. The most recent PDF version is available for download at dynon.com/docs. This manual is updated periodically, and it is important to use the most recent version when installing SkyView components.

Dynon suggests keeping a PDF version of the manual on a smartphone, tablet, or laptop computer while installing and configuring SkyView. Using the manual electronically allows quick navigation of the document, figures to be viewed in color, and keyword searches.

1.2 Document Iconography

The following icons are used in this guide:



This icon denotes information that merits special attention.



This icon denotes a helpful tip.

1.3 Reference Documents

The following documents support the information in this document:

- SkyView System Installation Guide

2 Connecting and Configuring ARINC-429 GPS Navigators

This section provides information for connecting and configuring SkyView and third-party GPS Navigators using Dynon's SV-ARINC-429 interface module.

For information about installing the SV-ARINC-429 and connecting it to SkyView, see the *Skyview System Installation Manual* document.

Connection to ARINC-429 capable GPS navigators via the SV-ARINC-429 provides advanced features such as GPS steering, CDI auto-scaling, and vertical guidance information from WAAS-enabled GPS receivers. The SV-ARINC-429 also enables VOR and localizer functionality if the third-party device is so equipped. With an SV-ARINC-429, SkyView's electronic HSI eliminates the need to install a conventional external HSI.

The SV-ARINC-429 has two ARINC-429 receivers and one transmitter. The single transmitter can connect to multiple devices that accept the ARINC-429 information that SkyView transmits. The SV-ARINC-429 also has a serial input that is designed to provide auxiliary information that ARINC-429 GPS outputs do not provide (such as altitude). SkyView needs this data to consider the input a valid and complete GPS position source. This input is not a general-purpose serial port and cannot be configured for other uses. Input coming into this serial port is assumed to be in Aviation format, which most ARINC-429 capable panel-mount GPS units can output.

2.1 SV-ARINC-429 Related Settings

SkyView supports up to two SV-ARINC-429 modules, but since most aircraft will only have one installed, the "MODULE 2" setting under SYSTEM SETUP > ARINC-429 is normally disabled. If the installation does have two SV-ARINC-429 modules, the serial numbers of each module are displayed to determine which module is which.

For each SV-ARINC-429 module, Set INPUT1 to the type of device (i.e., GPS 1, 2, 3, 4 or NAV 1, 2, 3, 4) connected to the ARINC-429 RX 1 A and B inputs (see [Figure 1](#)). Optionally, a "friendly" name (up to 7 characters) can be specified for each device using the NAVIGATION SOURCE DISP NAME setting. Some examples include: "430NAV" and "430GPS". If a friendly name is specified, it will be displayed on the HSI. If a friendly name is not specified, GPS 1, 2, 3, 4 or NAV 1, 2, 3, 4 will be displayed in the info item next to the HSI. For IFR GPS navigators, particularly the Garmin GNS and GTN series, the device name/number is also displayed at the top of the Flight Plan window.



Although POS X is a possible setting, it should not be used for ARINC devices.



Any GPS/NAV slots that are highlighted in red are already being used for other devices.

After identifying the device, INPUT SPEED parameter (HIGH or LOW) needs to be set according to output speed of the ARINC device(s). The SV-ARINC-429 has one ARINC output channel with 2 sets of pins on the connector for wiring convenience. If the ARINC device(s) can accept commands, configure OUTPUT SPEED appropriately.

If a device is connected to the ARINC-429 RX 2 A and B inputs (see [Figure 1](#)), repeat the above configuration for the INPUT2 parameter; otherwise, leave it set to NONE.

To allow SkyView to automatically change displayed data between INPUT1 and INPUT2, select ALLOW AUTO SWITCH: YES (LABEL 100P). If set to YES (LABEL 100P):

- If the source transmits the "100P" label (such as Garmin GNS/GTN series), SkyView will automatically switch inputs per the label. This allows the inputs to be remotely switched by data from the source, either when the CDI is changed, or automatic transition on approach.
- If data is being transmitted to INPUT1, but no data is being transmitted to INPUT2, INPUT1 will be displayed.
- If data is being transmitted to INPUT2, but no data is being transmitted to INPUT1, INPUT2 will be displayed.

To manually change displayed data between INPUT1 and INPUT2, select ALLOW AUTO SWITCH: NO.

2.2 Generic Electrical Connections

The following diagram depicts the typical electrical connections between GPS Navigator devices and an SV-ARINC-429.

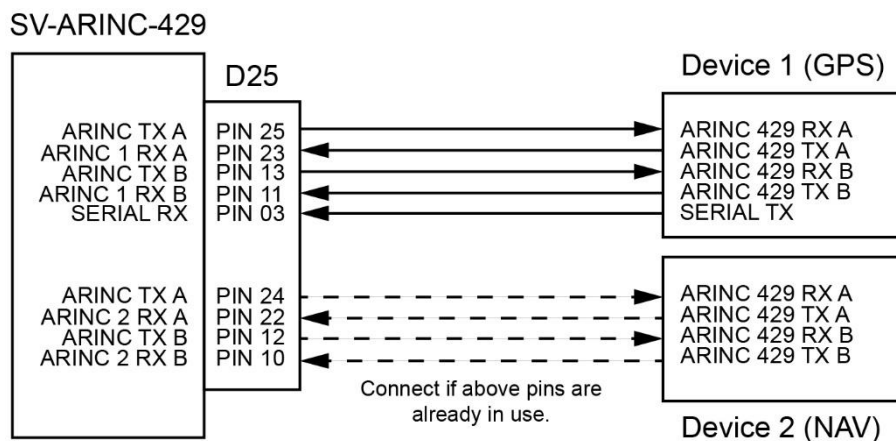

Figure 1: Typical GPS Navigator to SV-ARINC-429 Connections

2.3 Garmin GNS 4XX/5XX Series

Electrical Connections

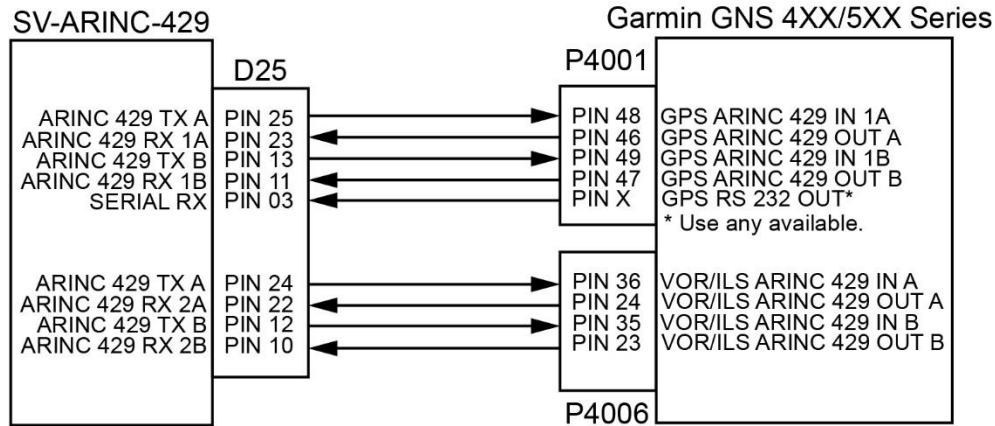

Figure 2: GNS 4XX/5XX Series to SV-ARINC-429 Electrical Connections

Garmin Settings

From the "Main ARINC 429 Config" page:

- In 1: High | EFIS/Airdata
- In 2: Unused by SkyView, configure as needed for other equipment
- Out: High | GAMA GRAPHICS 429
- SDI: Common
- VNAV: Enable Labels

From the "VOR / LOC / GS ARINC 429 Config" page:

- TX: High
- RX: High
- SDI: Common
- DME: Unused by SkyView

From the "MAIN RS232 CONFIG" page:

- Chan "#" Output: Aviation
- # = physically connected port number

SkyView Settings

From the SETUP MENU > SYSTEM SETUP > ARINC-429 menu:

- INPUT SPEED = HIGH
- INPUT 1 = GPS '#'
- NAVIGATION SOURCE DISP NAME = <enter device name up to 7 characters>



The name entered is displayed as the HSI source and the Flight Plan source (if the device outputs a Flight Plan).

- INPUT 2 = NAV '#'
- NAVIGATION SOURCE DISP NAME = <enter a device name up to 7 characters>



The name entered is displayed as the HSI source and the Flight Plan source (if the device outputs a Flight Plan).

- OUTPUT SPEED = HIGH
- ALLOW AUTO SWITCH = YES (LABEL 100P)



Setting this to YES (LABEL 100P) allows the GNS 4XX/5XX to tell SkyView to switch from GPS to ILS or back when on an ILS overlay approach. SkyView will display whatever mode the GNS 4XX/5XX tells SkyView. When in this mode, and not on an approach, switching between the NAV function and GPS function must be performed from the GNS4XX/5XX.

- ALLOW AUTO SWITCH: NO.



Setting this to NO allows manual selection of GPS and NAV functions from the GNS 4XX/5XX, as was done prior to SkyView S/W v10.0.

Optional Settings

If a Dynon SV-XPNDR-261 is being used for ADS-B Out capability, an additional serial output on the GNS 4XX/5XX should be set to "ADS-B+ OUT" format. That serial port should be connected to Pin 3 on the SV-XPNDR-261's harness via a 1.21k resistor, as described in the *SV-XPNDR-261 Installation and Configuration* section of the *SkyView System Installation Manual*.

To enable this functionality, go to SETUP > TRANSPONDER SETUP > GPS DATA to DIRECT and select GARMIN ADS-B/GARMIN ADS-B +.

2.4 Garmin GTN 6XX/7XX Series

Electrical Connections

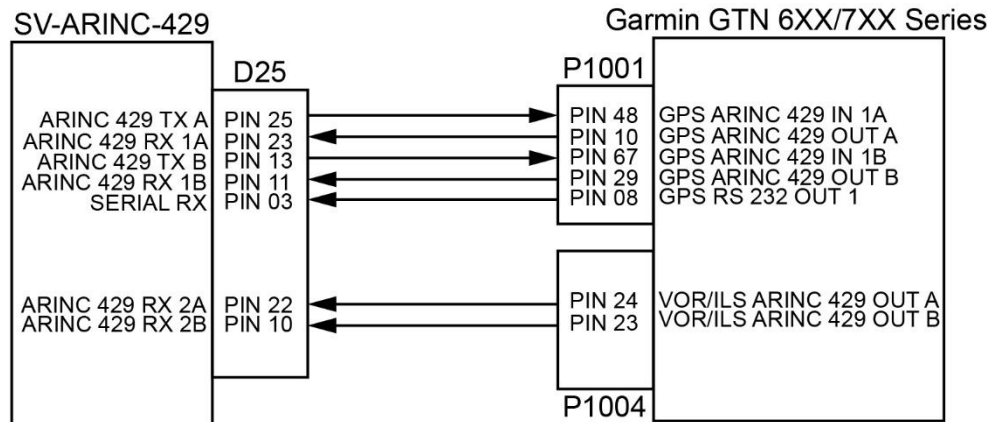

Figure 3: GTN 6XX/7XX Series to SV-ARINC-429 Electrical Connections

Garmin Settings

From the "ARINC 429 Configuration" page:

- In 1: High | EFIS Format 2
- In 2: Unused by SkyView, configure as needed for other equipment
- Out: High | GAMA Format 2
- SDI: Common

From the "VOR / LOC / GS Configuration" page:

- Nav Radio: Enabled
- ARINC 429 Configuration:
 - TX: High
 - SDI: Common
- Other Settings: Unused by SkyView

From the "RS-232 Configuration" page:

- RS232 1 Output: Aviation Output 1

SkyView Settings

From the SETUP MENU > SYSTEM SETUP > ARINC-429 menu:

- INPUT SPEED = HIGH
- INPUT 1 = GPS '#'
- NAVIGATION SOURCE DISP NAME = <enter device name up to 7 characters>



The name entered is displayed as the HSI source and the Flight Plan source (if the device outputs a Flight Plan).

- INPUT 2 = NAV '#'
- NAVIGATION SOURCE DISP NAME = <enter a device name up to 7 characters>



The name entered is displayed as the HSI source and the Flight Plan source (if the device outputs a Flight Plan).

- OUTPUT SPEED = HIGH
- ALLOW AUTO SWITCH = YES (LABEL 100P)



Setting this to YES (LABEL 100P) allows the GTN 6XX/7XX to tell SkyView to switch from GPS to ILS or back when on an ILS overlay approach. SkyView will display whatever mode the GTN 6XX/7XX tells SkyView. When in this mode, and not on an approach, switching between the NAV function and GPS function must be performed from the GTN 6XX/7XX.

- ALLOW AUTO SWITCH: NO.



Setting this to NO allows manual selection of GPS and NAV functions from the GTN 6XX/7XX, as was done prior to SkyView S/W v10.0.

Optional Settings

If a Dynon SV-XPNDR-261 is being used for ADS-B Out capability, an additional serial output on the GTN 6XX/7XX should be set to "ADS-B+ OUT" format. That serial port should be connected to Pin 3 on the SV-XPNDR-261's harness via a 1.21k resistor, as described in the *SV-XPNDR-261 Installation and Configuration* section of the *SkyView System Installation Manual*.

To enable this functionality, go to SETUP > TRANSPONDER SETUP > GPS DATA to DIRECT and select GARMIN ADS-B/GARMIN ADS-B +.

2.5 Garmin GNS 480 and Apollo CNX80

Electrical Connections

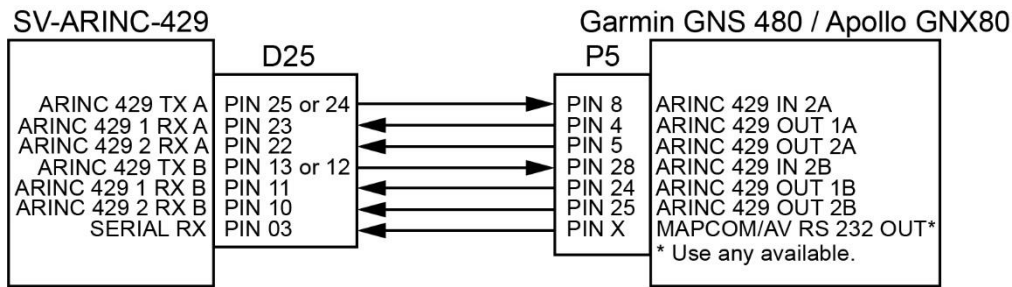

Figure 4: GNS 480 and Apollo CNX80 to SV-ARINC-429 Electrical Connections

Garmin Settings

From the "ARINC 429 Setup" page:

- CH_IN 1: Unused by SkyView, configure as needed for other equipment
- CH_IN 2: EFIS | HIGH | SYS1
- CH_IN 3: Unused by SkyView, configure as needed for other equipment
- CH_OUT 1: GAMA 429 GFX | HIGH | ALL
- CH_OUT 2: VOR/ILS | HIGH | ALL

From the "Serial Setup" page:

- CH #:
 - RX: Unused by SkyView
 - TX: MAPMX | 9600

From the "Resolver Interface" page:

- RESOLVER: NOT INSTALLED

SkyView Settings

From the SETUP MENU > SYSTEM SETUP > ARINC-429 menu:

- INPUT SPEED = HIGH
- INPUT 1 = GPS '#'
- NAVIGATION SOURCE DISP NAME = <enter device name up to 7 characters>



The name entered is displayed as the HSI source and the Flight Plan source (if the device outputs a Flight Plan).

- INPUT 2 = NAV '#'

- NAVIGATION SOURCE DISP NAME = <enter a device name up to 7 characters>



The name entered is displayed as the HSI source and the Flight Plan source (if the device outputs a Flight Plan).

- OUTPUT SPEED = HIGH
- ALLOW AUTO SWITCH = YES (LABEL 100P)



Setting this to YES (LABEL 100P) allows the GNS 480 to tell SkyView to switch from GPS to ILS or back when on an ILS overlay approach. SkyView will display whatever mode the GNS 480 tells SkyView. When in this mode, and not on an approach, switching between the NAV function and GPS function must be performed from the GNS 480.

- ALLOW AUTO SWITCH: NO.



Setting this to NO allows manual selection of GPS and NAV functions from the GNS 480, as was done prior to SkyView S/W v10.0.

Optional Settings

If a Dynon SV-XPNDR-261 is being used for ADS-B Out capability, an additional serial output on the GNS 480 should be set to "ADS-B+ OUT" format. That serial port should be connected to Pin 3 on the SV-XPNDR-261's harness via a 1.21k resistor, as described in the *SV-XPNDR-261 Installation and Configuration* section of the *SkyView System Installation Manual*.

To enable this functionality, go to SETUP > TRANSPONDER SETUP > GPS DATA to DIRECT and select GARMIN ADS-B/GARMIN ADS-B +.

2.6 Garmin GNC Series

Electrical Connections

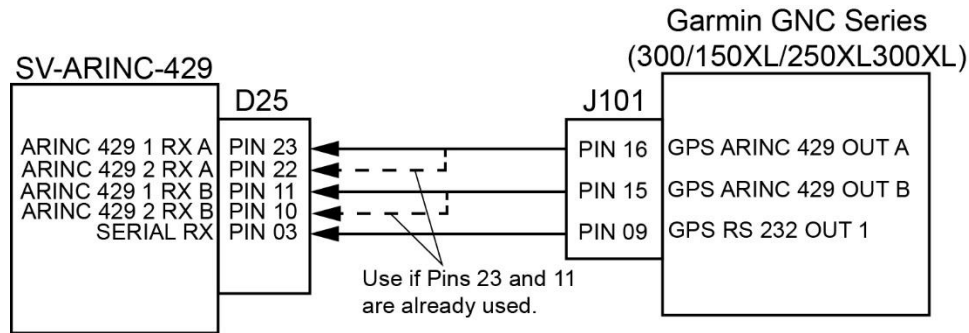

Figure 5: Garmin GNC Series to SV-ARINC-429 Electrical Connections

Garmin Settings

From the "ARINC 429 Configuration" page:

- In 1: High | EFIS Format 2
- In 2: Unused by SkyView, configure as needed for other equipment
- Out: High | GAMA Format 2
- SDI: Common

From the "VOR / LOC / GS Configuration" page:

- Nav Radio: Enabled
- ARINC 429 Configuration:
 - TX: High
 - SDI: Common
- Other Settings: Unused by SkyView

From the "RS-232 Configuration" page:

- RS232 1 Output: Aviation Output 1

SkyView Settings

From the SETUP MENU > SYSTEM SETUP > ARINC-429 menu:

- INPUT SPEED = HIGH
- INPUT 1 = GPS '#'
- NAVIGATION SOURCE DISP NAME = <enter device name up to 7 characters>



The name entered is displayed as the HSI source and the Flight Plan source (if the device outputs a Flight Plan).

- INPUT 2 = NAV '#'

- NAVIGATION SOURCE DISP NAME = <enter a device name up to 7 characters>



The name entered is displayed as the HSI source and the Flight Plan source (if the device outputs a Flight Plan).

- OUTPUT SPEED = HIGH
- ALLOW AUTO SWITCH = YES (LABEL 100P)



Setting this to YES (LABEL 100P) allows the GNC series device to tell SkyView to switch from GPS to ILS or back when on an ILS overlay approach. SkyView will display whatever mode the GNC series device tells SkyView. When in this mode, and not on an approach, switching between the NAV function and GPS function must be performed from the GNC series device.

- ALLOW AUTO SWITCH: NO.



Setting this to NO allows manual selection of GPS and NAV functions from the GNC series device, as was done prior to SkyView S/W v10.0.

Optional Settings

If a Dynon SV-XPNDR-261 is being used for ADS-B Out capability, an additional serial output on WAAS-enable GNC devices should be set to "ADS-B+ OUT" format. That serial port should be connected to Pin 3 on the SV-XPNDR-261's harness via a 1.21k resistor, as described in the *SV-XPNDR-261 Installation and Configuration* section of the *SkyView System Installation Manual*.

To enable this functionality, go to SETUP > TRANSPONDER SETUP > GPS DATA to DIRECT and select GARMIN ADS-B/GARMIN ADS-B +.

2.7 Garmin GPS 175/ / GNC 355

Electrical Connections

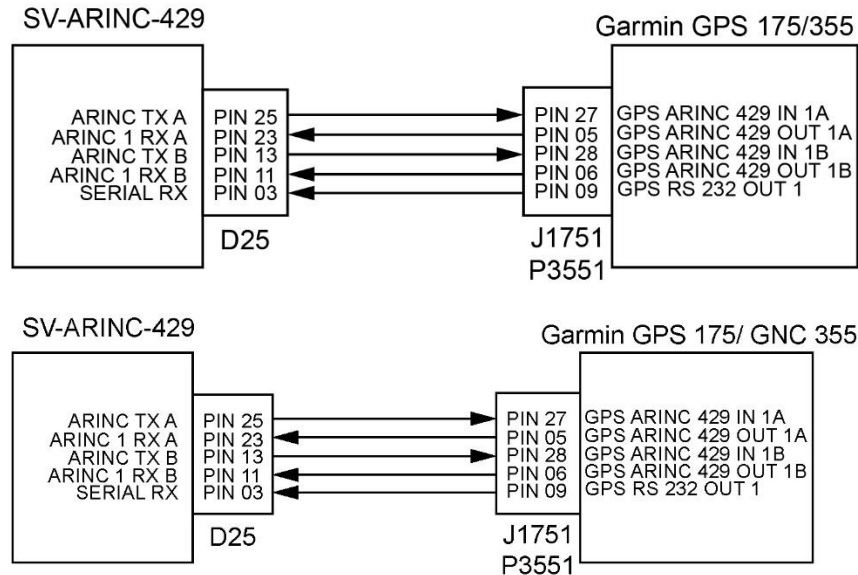

Figure 6: Garmin GPS 175/ / GNC 355 to SV-ARINC-429 Electrical Connections

Garmin Settings

From the "ARINC Configuration" page:

- ARINC RX Port 1:
 - Format: EFIS/ADC
 - Speed: High
- ARINC RX Port 2:
 - Format: Off
 - Speed: Low
- ARINC TX Port 1:
 - Format: GAMA Format 3
 - Speed: High
 - SDI: Common

From the "RS232 Configuration" page:

- Port 1: Aviation Output 1

SkyView Settings

From the SETUP MENU > SYSTEM SETUP > ARINC-429 menu:

- INPUT SPEED = HIGH
- INPUT 1 = GPS '#'
- NAVIGATION SOURCE DISP NAME = <enter device name up to 7 characters>



The name entered is displayed as the HSI source and the Flight Plan source (if the device outputs a Flight Plan).

- INPUT 2 = NONE
- NAVIGATION SOURCE DISP NAME = NONE

- OUTPUT SPEED = HIGH
- ALLOW AUTO SWITCH = YES

Optional Settings

If a Dynon SV-XPNDR-261 is being used for ADS-B Out capability, an additional serial output on GPS 175/ / GNC 355 should be set to "ADS-B+ OUT" format. That serial port should be connected to Pin 3 on the SV-XPNDR-261's harness via a 1.21k resistor, as described in the SV-XPNDR-261 Installation and Configuration section of the SkyView System Installation Manual.

To enable this functionality, go to SETUP > TRANSPONDER SETUP > GPS DATA to DIRECT and select GARMIN ADS-B/GARMIN ADS-B +.

2.8 Garmin GNX 375

Electrical Connections

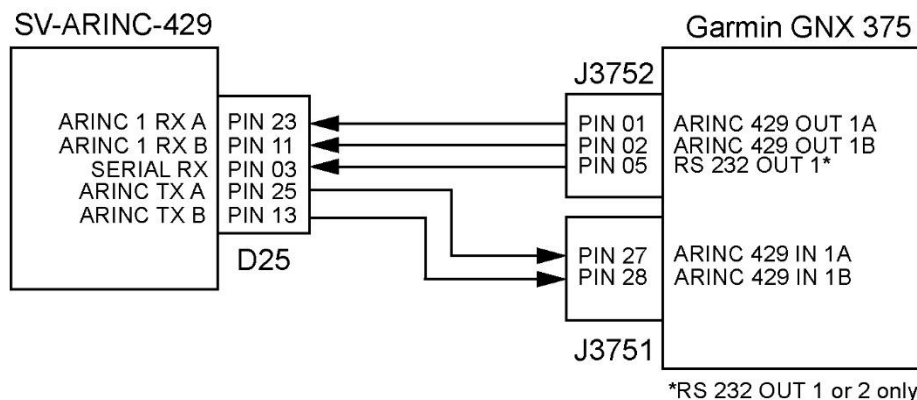

Figure 7: Garmin GNX 375 to SV-ARINC-429 Electrical Connections

Garmin Settings

From the "ARINC Configuration" page:

- ARINC RX Port 1:
 - Format: EFIS/ADC
 - Speed: High
- ARINC RX Port 2:
 - Format: Off
 - Speed: Low
- ARINC TX Port 1:
 - Format: GAMA Format 3
 - Speed: High
 - SDI: Common

From the "RS232 Configuration" page:

- Port 1: Aviation Output

SkyView Settings

From the SETUP MENU > SYSTEM SETUP > ARINC-429 menu:

- INPUT SPEED = HIGH
- INPUT 1 = GPS '#'
- NAVIGATION SOURCE DISP NAME = <enter device name up to 7 characters>



The name entered is displayed as the HSI source and the Flight Plan source (if the device outputs a Flight Plan).

- INPUT 2 = NONE

- NAVIGATION SOURCE DISP NAME = NONE
- OUTPUT SPEED = HIGH
- ALLOW AUTO SWITCH = YES

Optional Settings

If a Dynon SV-XPNDR-261 is being used for ADS-B Out capability, an additional serial output on GNX 375 should be set to "ADS-B+ OUT" format. That serial port should be connected to Pin 3 on the SV-XPNDR-261's harness via a 1.21k resistor, as described in the SV-XPNDR-261 Installation and Configuration section of the SkyView System Installation Manual.

To enable this functionality, go to SETUP > TRANSPONDER SETUP > GPS DATA to DIRECT and select GARMIN ADS-B/GARMIN ADS-B +.

2-82.9 Avidyne IFD 4XX/5XX Series

Electrical Connections

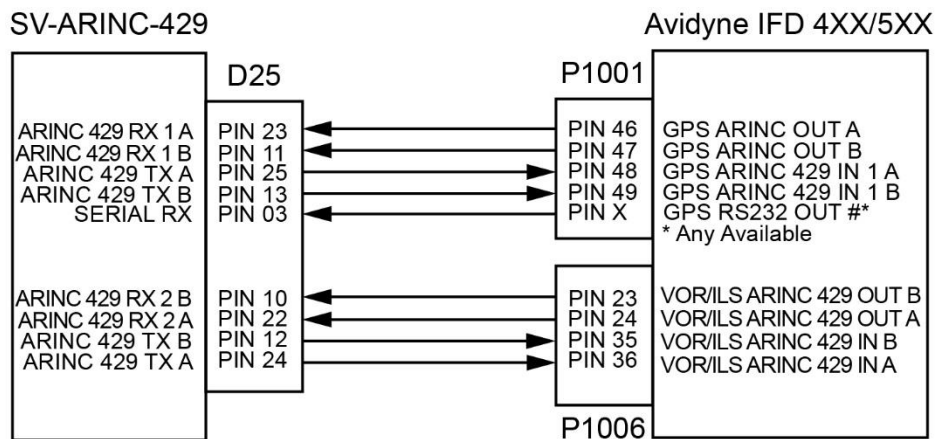

Below is optional connection to control and display
Avidyne COM radio on SkyView Display.

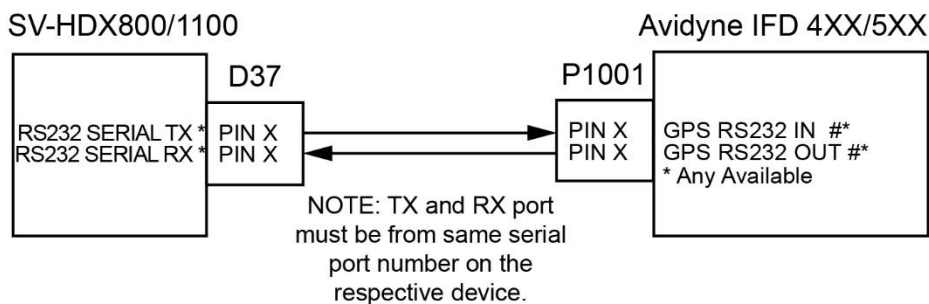

Figure 8: IFD 4XX/5XX Series to SV-ARINC-429 Electrical Connections

Avidyne Settings

From the "Main ARINC 429 Config" page:

- In 1:
 - Speed: High
 - Data: EFIS/Airdata
- In 2:
 - Speed: High
 - Data: Off
- Out 1:
 - Speed: High
 - Data: GAMA 429 Graphics
- Out 2:
 - Speed: High
 - Data: Off

- SDI: Common
- VNAV: Enable Labels

From the "VOR / LOC / GS ARINC 429 Config" page:

- RX:
 - Speed: High
 - Format: Off
- TX:
 - Speed: High
 - Format: VHF 429
- SDI: Common
- DME: Directed Freq 1

From the "MAIN RS232 CONFIG" page:

- CHNL # (Setting for Avidyne COM Radio):
 - Input: VhfCtrl
 - Output: VhfCtrl
- CHNL # (Setting for SV-ARINC-429 RS-232 Input):
 - Input: Off (may be used for other devices)
 - Output: Aviation

= physically connected port number

SkyView Settings

From the SETUP MENU > SYSTEM SETUP > ARINC-429 menu:

- INPUT SPEED = HIGH
- INPUT 1 = GPS '#'
- NAVIGATION SOURCE DISP NAME = <enter device name up to 7 characters>



The name entered is displayed as the HSI source and the Flight Plan source (if the device outputs a Flight Plan).

- INPUT 2 = NAV '#'
- NAVIGATION SOURCE DISP NAME = <enter a device name up to 7 characters>



The name entered is displayed as the HSI source and the Flight Plan source (if the device outputs a Flight Plan).

- OUTPUT SPEED = HIGH

- ALLOW AUTO SWITCH = YES (LABEL 100P)



Setting this to YES (LABEL 100P) allows the IFD 4XX/5XX to tell SkyView to switch from GPS to ILS or back when on an ILS overlay approach. SkyView will display whatever mode the IFD 4XX/5XX tells SkyView. When in this mode, and not on an approach, switching between the NAV function and GPS function must be performed from the IFD 4XX/5XX.

From the SETUP MENU > SYSTEM SETUP > SERIAL PORT SETUP > SERIAL PORT '#' SETUP > SERIAL IN DEVICE:

1. Select GARMIN / APOLLO SL40 or GARMIN GNC 255 A/B. This will automatically set the SERIAL IN/OUT BAUD RATE and SERIAL OUT DEVICE.
2. Enter SETUP MENU > SYSTEM SETUP > PRIMARY COM, and then select GARMIN / APOLLO SL40 or GARMIN GNC 255 A/B.
3. Enter SETUP MENU > SYSTEM SETUP > DISPLAY COM IN TOP BAR, and then select YES.

Optional Settings

If a Dynon SV-XPNDR-261 is being used for ADS-B Out capability, an additional serial output on the IFD 4XX/5XX should be set to "ADS-B+ OUT" format. That serial port should be connected to Pin 3 on the SV-XPNDR-261's harness via a 1.21k resistor, as described in the *SV-XPNDR-261 Installation and Configuration* section of the *SkyView System Installation Manual*.

To enable this functionality, go to SETUP > TRANSPONDER SETUP > GPS DATA to DIRECT and select AVIDYNE IFD.

3 Connecting and Configuring Serial Devices

Setting up serial communication between third-party devices and SkyView can be complex. This section provides general guidance for the most common devices and situations.

A SkyView display unit includes five general purpose RS-232 serial ports (see [Table 1](#) for details) for use with compatible equipment. SkyView components that use RS-232 serial ports for communication include the SV-GPS-250/2020, SV-XPNDR-261/262, and SV-ADSB-470/472. For information about connecting those components to SkyView, see the *Skyview System Installation Manual* document.



Serial Port 5 is reserved for SV-GPS-250/2020 connection. The SkyView D37 wire harness includes serial TX, RX, ground, and power wires that match the wire colors on the SV-GPS-250/2020.

The serial port transmit (TX) and receive (RX) wire sets are twisted together in a SkyView D37 wire harness. All devices connected to SkyView via serial connection must share a common power and ground with the installed SkyView display unit(s).

Third-party devices commonly used with SkyView include transponders (with serial port inputs), NAV radios such as Garmin SL30, COM radios such as Garmin SL40, GPS devices such as the Garmin 96 series, the Vertical Power VP-X system, and Emergency Location Transmitters (ELTs). Additionally, a PC or external serial data logger can be connected and used to record real-time ADAHRS and EMS data that can be output by SkyView.

Transponders with serial altitude input can be directly connected to a display unit. To interface a SkyView display to a gray code transponder, a Dynon Avionics Encoder Serial-to-Gray Code Converter Module (Dynon Avionics P/N 100362-000) is required (see [Section 3.2.4: Gray Code Transponders](#) for more information).

If SkyView includes more than one display unit, each external serial device's serial TX wire needs to be connected to each display unit so that it can send information to each display unit individually. Information that is received via serial connection is not automatically shared between multiple SkyView display units. Additionally, if the serial device can receive information from SkyView, that device's RX wire must also be connected to each SkyView display unit. For redundancy, SkyView has special hardware to allow multiple TX lines to be connected. It is required that all connections to/from a particular serial device be connected to the same SkyView display unit's serial port on every display unit in the SkyView system.



SkyView systems installed prior to SkyView Software v2.6 may require wiring changes to accommodate connection to each display unit. Specifically, if the system has multiple display units and the transponder is utilizing the serial altitude encoder output, the transponder would have been connected to only one displayed unit when the SkyView system was installed and configured. As of v2.6, transponders (and other serial devices) must be connected to each SkyView display unit in the system to work correctly.

Table 1: SkyView Display Unit Serial Port Connections

SERIAL PORT	WIRE FUNCTION	D37 HARNESS WIRE COLORS
1	TX	Brown with Orange stripe
	RX	Brown with Violet stripe
2	TX	Yellow with Orange stripe
	RX	Yellow with Violet stripe
3	TX	Green with Orange stripe
	RX	Green with Violet stripe
4	TX	Blue with Orange stripe
	RX	Blue with Violet stripe
5	SV-GPS-250/2020 TX	Gray with Orange stripe
	SV-GPS-250/2020 RX	Gray with Violet stripe
	SV-GPS-250/2020 Power	Solid Orange
	SV-GPS-250/2020 Ground	Solid Black



For serial device communication, the TX terminal in the serial port of the transmitting device must be connected to the RX terminal in the serial port of the receiving device.



To prevent the loss of data communication in the event of a SkyView display unit failure, each serial device must be connected to the same serial port on all SkyView display units installed in the system.

3.1 General Serial Connection Procedure

The following is a general procedure for serial connection between SkyView display units and third-party devices:



It is the installer's responsibility to determine how to connect third-party serial devices to a SkyView display unit's serial ports so that serial inputs and outputs work correctly.

1. Identify an unused serial port on SkyView display unit.
2. Make electrical connections to third-party device in accordance with device manufacturer's instructions.



If the SkyView system has more than one display unit, make sure the same electrical connections are made to all display units.

3. Under SETUP MENU > SYSTEM SETUP > SERIAL PORT SETUP, configure identified serial port on the SkyView display unit(s) in accordance with device manufacturer's instructions.
4. When the serial port configuration is complete, perform a final check:
 - a. Power down all displays except #1. Verify all serial port devices are working - transponder, GPS, radios, etc.
 - b. Power down all displays except #2. Verify all serial port devices are working - transponder, GPS, radios, etc.
 - c. Power down all displays except #3. Verify all serial port devices are working - transponder, GPS, radios, etc.



A SkyView display unit serial port can be configured to communicate with one device on TX and a different device on RX, but when doing so, the TX and RX speeds must be the same.

3.2 Traffic Devices

SkyView can receive and display aircraft traffic (ADS-B and TIS) data from third-party devices, as well as any other devices that output traffic data in a manner that emulates the Garmin TIS Traffic format, including:

- Garrecht / AIR Avionics TRX-1500,
- NavWorx ADS-B receiver,
- Zaon XRX.

Only one device can provide traffic information to SkyView at any moment. If more than one device capable of providing traffic is connected to SkyView, then the devices will provide traffic information based on the completeness of the traffic portrait they provide with the following priority:

1. SV-ADSB-470/472 with a full traffic portrait (ADS-B OK):

An ADS-B ground station is reporting, and that ground station is receiving radar traffic. This is only possible if the system has an ADS-B Out device such as an SV-XPNDR-261/262 or Garmin GTX 330ES transponder. In this case the ADS-B system delivers all known ADS-B equipped traffic, and all radar targets that FAA radar system can see.

2. SV-ADSB-472 with an incomplete traffic portrait (ADS-B NO RADAR):

SkyView will annunciate "No Radar" traffic when it has ADS-B reception capability, but that ADS-B reception does not include either ADS-B ground station coverage or radar targets included in the ground-based ADS-B traffic reports. Thus, the ADS-B ground station is not able to convey a full traffic picture and SkyView cannot present all possible detectable traffic.

3. TIS transponder from SV-XPNDR-261/262 or Garmin GTX 330 (when in an active TIS coverage area).
4. FLARM device.
5. ZAON device.
6. SV-ADSB-470 with an incomplete traffic portrait (ADS-B NO RADAR):
(Same as SV-ADSB-472 above.)

3.2.1 Garmin GTX 3XX Series

To enable traffic on SkyView with a Garmin GTX 3XX series transponder, both the serial TX and serial RX between the SkyView display unit(s) and the device must be connected and configured. The SkyView display unit(s) and the device must also have a common ground.



If the SkyView system has more than one display unit, make sure the same electrical connections are made to all display units.

The GTX 3XX series transponder also needs to be configured to transmit traffic data (ADS-B or TIS). Note that ADS-B requires a TSO'd GPS position. See manufacturer's documentation for configuring the device's serial port(s).

To configure SkyView for a GTX 3XX series transponder:

1. On each display unit, go to SETUP MENU > SYSTEM SETUP > SERIAL PORT SETUP > SERIAL PORT # SETUP > SERIAL IN DEVICE, and then select GARMIN GTX 327, GARMIN GTX 330, GARMIN GTX 330ES, or GARMIN TIS TRAFFIC (for those not listed).
2. On each display unit, go to SETUP MENU > SYSTEM SETUP > SERIAL PORT SETUP > SERIAL PORT # SETUP > SERIAL OUT DEVICE, and then select ICARUS ALTITUDE 100ft or ICARUS ALTITUDE 10ft.
3. On each display unit, go to SETUP MENU > SYSTEM SETUP > AIRCRAFT INFORMATION > TRANSPONDER HEX CODE > (set to same code as configured in GTX 300).

3.2.1.1 Garmin GTX 3XX Series Product Status

SkyView can display the status of a Garmin GTX 3XX series transponder. To enable this feature, the SkyView display unit(s) serial RX(s) must be connected and configured to the device's serial TX. The SkyView display unit(s) and the device must also have a common ground.



If the SkyView system has more than one display unit, make sure the same electrical connections are made to all display units.

The GTX 3XX series transponder also needs to be configured to transmit "REMOTE + TIS". See manufacturer's documentation for configuring the device's serial port(s).

To configure SkyView to display the status of a GTX 3XX series transponder:

1. On each display unit, go to SETUP MENU > SYSTEM SETUP > SERIAL PORT SETUP > SERIAL PORT # SETUP > SERIAL IN DEVICE, and then select GARMIN GTX 327, GARMIN GTX 330, GARMIN GTX 330ES, or GARMIN TIS TRAFFIC (for those not listed).
2. On each display unit, go to SETUP MENU > SYSTEM SETUP > SERIAL PORT SETUP > SERIAL PORT # SETUP > SERIAL OUT DEVICE, and then select ICARUS ALTITUDE 100ft or ICARUS ALTITUDE 10ft.

3. On each display unit, go to SETUP MENU > SYSTEM SETUP > AIRCRAFT INFORMATION > TRANSPONDER HEX CODE > (set to same code as configured in GTX 300).

3.2.2 Transponders and Other Devices

To enable traffic on SkyView with a device that emulates Garmin's TIS Traffic format, both the serial TX and serial RX between the SkyView display unit(s) and the device must be connected and configured. The SkyView display unit(s) and the device must also have a common ground.



If the SkyView system has more than one display unit, make sure the same electrical connections are made to all display units.

The transponder also needs to be configured to transmit TIS. See manufacturer's documentation for configuring the device's serial port(s).

To configure SkyView for devices that emulate Garmin's TIS Traffic format:

- On each display unit, go to SETUP MENU > SYSTEM SETUP > SERIAL PORT SETUP > SERIAL PORT # SETUP > SERIAL IN DEVICE, and then select GARMIN TIS TRAFFIC (associated parameters are automatically set).

3.2.3 External Altitude Encoders

SkyView supports serial external altitude encoders that use the Icarus/Garmin format.

3.2.3.1 Using Non-Dynon Altitude Data

The SV-XPNDR-261/262 transponder can use data from an external altitude encoder instead of the internal SkyView ADAHRS-generated pressure altitude. However, the altitude displayed by SkyView on the PFD page is always sourced from SkyView ADAHRS data.

To enable this feature, the SkyView display unit(s) serial RX(s) must be connected and configured to the device's serial TX. The SkyView display unit(s) and the device must also have a common ground.



If the SkyView system has more than one display unit, make sure the same electrical connections are made to all display units.

The external altitude encoder also needs to be configured to transmit altitude data. See manufacturer's documentation for configuring the device's serial ports.

To configure SkyView to use serial external altitude encoder data:

- On each display, go to SETUP MENU > SYSTEM SETUP > SERIAL PORT SETUP > SERIAL PORT # SETUP > SERIAL IN DEVICE, and then select ICARUS/GARMIN ALTITUDE.

3.2.3.2 Using Dynon Altitude Data

SkyView can output altitude data to transponders that receive serial altitude data input. To enable this feature, the SkyView display unit(s) serial TX(s) must be connected and configured to the device's serial RX. The SkyView display unit(s) and the device must also have a common ground.



If the SkyView system has more than one display unit, make sure the same electrical connections are made to all display units.

The external altitude encoder also needs to be configured to receive altitude data. See manufacturer's documentation for configuring the device serial ports.

SkyView outputs its altitude measurements in two different formats. Either format can be used on any of the serial ports. The formats described in [Table 2](#) and [Table 3](#) will function properly whether this altitude encoder functionality is used or not. The SkyView system encoder output reports pressure altitude. Therefore, the SkyView indicated altitude will only match the reported barometric altitude put out by the encoder when the SkyView barometric adjustment is set to 29.92.



A SkyView ADAHRS must be installed for the altitude encoder output feature to function.

Table 2: Icarus Format

ICARUS	
Used by	Garmin GTX330/ES (Garmin serial port must be set to Icarus input), Garmin GTX327 (Garmin serial port must be set to Icarus input), Garmin GTX328 (Garmin serial port must be set to Icarus input), Icarus, Trimble
Baud rate	9600
Format	ALT, space, five (5) altitude bytes, carriage return
Example message	ALT 05200[CR]

Table 3: Dynon Avionics Serial-to-Gray Code Converter Format

DYNON AVIONICS CONVERTER	
Used by	Dynon Avionics Encoder Serial-to-Parallel Converter, Garmin AT (formerly UPS Aviation Technologies) Garmin SL70 (same unit as Garmin AT)
Baud rate	1200
Format	#AL, space, +/-sign, five (5) altitude bytes, T+25, checksum, carriage return
Example message	#AL +05200T+25D7[CR]

Configure the serial port on each display appropriately. See [Section 3.1: General Serial Connection Procedure](#) for guidance.

3.2.4 Gray Code Transponders

To use SkyView's altitude encoder functionality with a Gray Code transponder, configure the serial port on each display SETUP MENU > SYSTEM SETUP > SERIAL PORT SETUP > SERIAL PORT X SETUP:

- Select SERIAL IN DEVICE: and select the device from the list.
- Select SERIAL OUT DEVICE: and select the device from the list.

3.2.5 TIS Format Traffic Output

Skyview can output TIS traffic for display on third-party avionics devices that can receive traffic in TIS format. To enable this feature, the SkyView display unit(s) serial TX(s) must be connected configured to the device's serial RX, and they must share a common ground. See the manufacturer's documentation for configuring the device to receive TIS traffic.



Only the actual TIS traffic from an SV-XPNDR-261 is included in the serial data stream. This stream does not include ADS-B, FLARM, ZAON, or other traffic sources that may be available to SkyView.

To configure SkyView to output TIS traffic:

- On each display unit, go to SETUP MENU > SYSTEM SETUP > SERIAL PORT SETUP, SERIAL PORT # SETUP > SERIAL OUT DEVICE, and then select TIS OUT (330 FORMAT).

3.3 NAV / COM Devices

3.3.1 Val Avionics NAV 2000 Transceiver

To work with SkyView, the NAV 2000 must have v1.10 Software (minimum). The Software version is displayed during the NAV 2000 startup.

To connect and configure the NAV 2000:

1. Connect SERIAL RX Pin 4 (Connector P1) to a SkyView serial TX.
2. Connect SERIAL TX Pin 5 (Connector P1) to a SkyView serial RX.
3. Ensure a shared ground between the SkyView display unit and SERIAL GROUND Pin 3 (Connector P1).



If there is more than one display unit in SkyView system, repeat same connections to all display units.

4. Enter configuration page by pressing and holding both the left and right knobs while the unit is starting up until the display shows the last used active frequency and the first configuration page: **A108.00 Rs l:xxx* ('x' is placeholder for resolver setting).
5. Rotate left inner (small) encoder to show 'Non' in the section following **Rs l:*.
6. Push and hold both encoder buttons to exit from the configuration pages.

To configure SkyView:

1. Enter SETUP MENU > SYSTEM SETUP > SERIAL PORT SETUP > SERIAL PORT '#'
SETUP > SERIAL IN DEVICE, and then select VAL AVIONICS NAV 2000. This will automatically set the SERIAL IN/OUT BAUD RATE and SERIAL OUT DEVICE.
2. Set SERIAL IN FUNCTION to NAV 1, 2, 3, or 4. If the NAV 2000 is the only NAV device, select NAV 1.
3. Set NAVIGATION SOURCE DISPLAY NAME to NAV2000 (suggested). The name entered here is displayed as the HSI source and the Flight Plan Source (if this device outputs a flight plan).
4. Enter SETUP MENU > SYSTEM SETUP > PRIMARY COM, and then select NONE. Select SV-COM-PANEL if an SV-COM-760, -T25/T8, -425 is installed.
5. Enter SETUP MENU > SYSTEM SETUP > DISPLAY COM IN TOP BAR, and then select NO. Select YES if an SV-COM-760, -T25/T8, -425 is installed.

3.3.2 Garmin SL30 COM Radio / NAV Receiver

In addition to the NAV radio functions of the SL30, SkyView can display COM radio information from the SL30 on the top bar of the SkyView display unit(s) and send COM frequencies to the SL30 (TUNE COM).

To connect and configure the SL30:

1. Connect SERIAL RX Pin 4 (RxD1) to a SkyView serial TX.
2. Connect SERIAL TX Pin 5 (TxD1) to a SkyView serial RX.
3. Ensure a shared ground between the SkyView display unit and the SL30.



If there is more than one display unit in SkyView system, repeat same connections to all display units.

4. Configure serial port on SL30 according to manufacturer's instructions. The Indicator Head Type should be set to NONE.

To configure SkyView:

1. Enter SETUP MENU > SYSTEM SETUP > SERIAL PORT SETUP > SERIAL PORT '#'
SETUP > SERIAL IN DEVICE, and then select GARMIN / APOLLO SL30. This will automatically set the SERIAL IN/OUT BAUD RATE and SERIAL OUT DEVICE.
2. Set SERIAL IN FUNCTION to NAV 1, 2, 3, or 4. If the SL30 is the only NAV device, select NAV 1.
3. Set NAVIGATION SOURCE DISPLAY NAME to SL30 (suggested). The name entered here is displayed as the HSI source and the Flight Plan Source (if this device outputs a flight plan).
4. Enter SETUP MENU > SYSTEM SETUP > PRIMARY COM, and then select GARMIN / APOLLO SL30.
5. Enter SETUP MENU > SYSTEM SETUP > DISPLAY COM IN TOP BAR, and then select YES.

3.3.3 GNC 255 COM Radio / NAV Receiver

SkyView can send frequencies to the GNC 255's standby frequency.

To connect and configure the GNC 255:

1. Connect SERIAL RX Pin 16 (P2001) to a SkyView serial TX.
2. Connect SERIAL RX Pin 1 (P2001) to a SkyView serial RX.
3. Ensure a shared ground between the SkyView display unit and the GNC 255.



If there is more than one display unit in SkyView system, repeat same connections to all display units.

4. Configure serial port on GNC 255 according to manufacturer's instructions. The I/O Mode should be set to NMEA, and the CDI Indicator should be set to NONE.

To configure SkyView:

1. Enter SETUP MENU > SYSTEM SETUP > SERIAL PORT SETUP > SERIAL PORT '#'
SETUP > SERIAL IN DEVICE, and then select GARMIN GNC 255 A/B. This will automatically set the SERIAL IN/OUT BAUD RATE and SERIAL OUT DEVICE.
2. Set SERIAL IN FUNCTION to NAV 1, 2, 3, or 4. If the GNC 255 is the only NAV device, select NAV 1.
3. Set NAVIGATION SOURCE DISPLAY NAME to GNC255 (suggested). The name entered here is displayed as the HSI source and the Flight Plan Source (if this device outputs a flight plan).
4. Enter SETUP MENU > SYSTEM SETUP > PRIMARY COM, and then select GARMIN GNC 255 A/B.
5. Enter SETUP MENU > SYSTEM SETUP > DISPLAY COM IN TOP BAR, and then select YES.

3.3.4 Garmin SL40 COM Radio

SkyView can display COM radio information from the SL40 on the SkyView top bar and send COM frequencies to the SL40 (TUNE COM).

To connect and configure the SL40:

1. Connect SERIAL RX Pin 10 (RxD1) to a SkyView serial TX.
2. Connect SERIAL TX Pin 3 (RxD1) to a SkyView serial RX.
3. Ensure a shared ground between the SkyView display unit and the SL40.



If there is more than one display unit in SkyView system, repeat same connections to all display units.

4. Configure serial port on SL40 according to manufacturer's instructions.

To configure SkyView:

1. Enter SETUP MENU > SYSTEM SETUP > SERIAL PORT SETUP > SERIAL PORT '#'
SETUP > SERIAL IN DEVICE, and then select GARMIN / APOLLO SL40. This will
automatically set the SERIAL IN/OUT BAUD RATE and SERIAL OUT DEVICE.
2. Enter SETUP MENU > SYSTEM SETUP > PRIMARY COM, and then select GARMIN /
APOLLO SL40.
3. Enter SETUP MENU > SYSTEM SETUP > DISPLAY COM IN TOP BAR, and then select
YES.

3.3.5 Garmin GTR 200 and GTR 225 COM Radios

SkyView can display COM radio information from the GTR 200 and GTR 225 on the SkyView top bar and push COM frequencies to the GTR 200 and GTR 225 (TUNE COM).

SkyView does not push database information for the GTR 200 to enable the GTR 200's "Nearest or Flight Plan Airports" feature.

To connect and configure the GTR 200 and GTR 225:

1. Connect RS232 IN Pin 24 to a SkyView serial TX.
2. Connect RS232 OUT Pin 23 to a SkyView serial RX.
3. Ensure a shared ground between the SkyView display unit and the GTR 200 or GTR 225.



If there is more than one display unit in SkyView system, repeat same connections to all display units.

4. Configure serial port on GTR 200 or GTR 225 according to manufacturer's instructions.

To configure SkyView:

1. Enter SETUP MENU > SYSTEM SETUP > SERIAL PORT SETUP > SERIAL PORT '#'
SETUP > SERIAL IN DEVICE, and then select GARMIN GTR 200 or GARMIN GTR 225
A/B. This will automatically set the SERIAL IN/OUT BAUD RATE and SERIAL OUT
DEVICE.
2. Enter SETUP MENU > SYSTEM SETUP > PRIMARY COM, and then select GARMIN
GTR 200 or GARMIN GTR 225 A/B.
3. Enter SETUP MENU > SYSTEM SETUP > DISPLAY COM IN TOP BAR, and then select
YES.

3.3.6 Trig TY91 25KHz and 8.33/25KHz COM Radios

SkyView can display COM radio information from the TY91 on the top bar of SkyView display unit(s) and push COM frequencies to the TY91 (TUNE COM).

To connect and configure the TY91:

1. Connect RS232 IN Pin 6 (TC90) to a SkyView serial TX.
2. Connect RS232 OUT Pin 5 (TC90) to a SkyView serial RX.
3. Ensure a shared ground between the SkyView display unit and the TY91.



If there is more than one display unit in SkyView system, repeat same connections to all display units.

4. Configure serial port on TY91 according to manufacturer's instructions.

To configure SkyView:

1. Enter SETUP MENU > SYSTEM SETUP > SERIAL PORT SETUP > SERIAL PORT '#'
SETUP > SERIAL IN DEVICE, and then select TRIG TY9X 25KHz ONLY or TRIG TY9X
8.33/25KHz. This will automatically set the SERIAL IN/OUT BAUD RATE and SERIAL
OUT DEVICE.
2. Enter SETUP MENU > SYSTEM SETUP > PRIMARY COM, and then select TRIG TY9X
25KHz ONLY or TRIG TY9X 8.33/25KHz. Select SV-COM-PANEL if an SV-COM-T25/T8
is installed.
3. Enter SETUP MENU > SYSTEM SETUP > DISPLAY COM IN TOP BAR, and then select
YES.

3.3.7 f.u.n.k.e. Avionics ATR833

SkyView can display COM radio information from the ATR833 on the SkyView top bar and push COM frequencies to the ATR833 (TUNE COM).

To connect and configure the ATR833:

1. Connect DATA RX Pin 9 (D25) to a SkyView serial TX.
2. Connect DATA TX Pin 22 (D25) to a SkyView serial RX.
3. Ensure a shared ground between the SkyView display unit and the ATR 833.



If there is more than one display unit in SkyView system, repeat same connections to all display units.

4. Configure serial port on ATR 833 according to manufacturer's instructions.

To configure SkyView:

1. Enter SETUP MENU > SYSTEM SETUP > SERIAL PORT SETUP > SERIAL PORT '#'
SETUP > SERIAL IN DEVICE, and then select FUNKE ATR833. This will automatically
set the SERIAL IN/OUT BAUD RATE and SERIAL OUT DEVICE.
2. Enter SETUP MENU > SYSTEM SETUP > PRIMARY COM, and then select FUNKE
ATR833.
3. Enter SETUP MENU > SYSTEM SETUP > DISPLAY COM IN TOP BAR, and then select
YES.

3.3.8 MGL Avionics V6 and V10 COM Radios

The V6 and V10 do not transmit status or frequencies via serial port, so V6/V10 information cannot be displayed on the top bar of the SkyView display unit(s). SkyView can push COM radio frequencies to the V6 and V10 (TUNE COM).

To connect and configure the V6 and V10:

1. Connect DATA1 - IN (D25 Pin 3) to a SkyView serial TX.
2. Ensure a shared ground between the SkyView display unit and the V6/V10.



If there is more than one display unit in SkyView system, repeat same connections to all display units.

3. Configure serial port on V6/V10 according to manufacturer's instructions.

To configure SkyView:

1. Enter SETUP MENU > SYSTEM SETUP > SERIAL PORT SETUP > SERIAL PORT '#'
SETUP > SERIAL IN DEVICE, and then select MGL V6/V10. This will automatically set
the SERIAL IN/OUT BAUD RATE and SERIAL OUT DEVICE.



Although there is no V6/V10 serial TX to SkyView serial RX connection, SERIAL IN DEVICE must be configured as described.

2. Enter SETUP MENU > SYSTEM SETUP > PRIMARY COM, and then select MGL
V6/V10.
3. Enter SETUP MENU > SYSTEM SETUP > DISPLAY COM IN TOP BAR, and then select
NO.

3.3.9 Icom IC-A210 COM Radio

The IC-A210 does not transmit status or frequencies via serial port, so IC-A210 information cannot be displayed on the top bar of the SkyView display unit(s). SkyView can push COM radio frequencies to the IC-A210 (TUNE COM).

Ensure that your A210 is running Software version 1.53 or newer. This feature will not work with old Software. Contact Icom for details on upgrading your radio Software.

To connect and configure the IC-A210:

1. Connect SERIAL RX (Molex Pin 2 / D15 Pin 10) to a SkyView serial TX.
2. Ensure a shared ground between the SkyView display unit and the IC-A210.



If there is more than one display unit in SkyView system, repeat same connections to all display units.

3. Configure serial port on IC-A210 according to manufacturer's instructions.

To configure SkyView:

1. Enter SETUP MENU > SYSTEM SETUP > SERIAL PORT SETUP > SERIAL PORT '#'
SETUP > SERIAL IN DEVICE, and then select ICOM A210. This will automatically set the SERIAL IN/OUT BAUD RATE and SERIAL OUT DEVICE.



Although there is no IC-A210 serial TX to SkyView serial RX connection, SERIAL IN DEVICE must be configured as described.

2. Enter SETUP MENU > SYSTEM SETUP > PRIMARY COM, and then select ICOM A210.
3. Enter SETUP MENU > SYSTEM SETUP > DISPLAY COM IN TOP BAR, and then select NO.

3.4 Portable GPS Devices

SkyView can accept GPS data in NMEA format from other GPS devices' data streams.

3.4.1 Bendix / King SkyMap III

To connect and configure SkyMap III:

1. Connect DATA OUT (TX DATA) Pin 2 to a SkyView serial RX.
2. Ensure a shared ground between the SkyView display unit and the SkyMap III.



If there is more than one display unit in the SkyView system, repeat same connections to all display units.

3. From SkyMap III's "Data Input/Output Setup and Test" screen, make sure Data Output is set to NMEA 0183 4800 BAUD and other parameters are set according to manufacturer's instructions.

To configure SkyView:

1. Enter SETUP MENU > SYSTEM SETUP > SERIAL PORT SETUP > SERIAL PORT '#'
SETUP > SERIAL IN DEVICE, and then select BENDIX SKYMAP III. This will automatically set the SERIAL IN/OUT BAUD RATE and SERIAL OUT DEVICE.
2. Make sure SERIAL OUT DEVICE is set to (NOT SET).
3. Make sure SERIAL OUT DEVICE is set to NONE.
4. Set SERIAL IN FUNCTION to POS 1, 2, 3. If the SkyMap III is the only GPS device, select POS 1. If the SkyMap III is being used as a backup GPS source to an SV-GPS-250/2020 or another GPS device, select POS 2 or 3 as appropriate.

3.4.2 Garmin Portable GPS Devices

To connect and configure Garmin portable GPS devices:

1. Connect DATA OUT TX (blue wire on Power/Data Cable) to a SkyView serial RX.
2. Ensure a shared ground between the SkyView display unit and the Garmin GPS device.



If there is more than one display unit in the SkyView system, repeat same connections to all display units.

3. From the device's "Interface Setup" screen, make sure Serial Data Format is set to NMEA In/NMEA Out and other parameters are set according to manufacturer's instructions.

To configure SkyView:

1. Enter SETUP MENU > SYSTEM SETUP > SERIAL PORT SETUP > SERIAL PORT '#'
SETUP > SERIAL IN DEVICE, and then select the Garmin GPS device. This will
automatically set the SERIAL IN/OUT BAUD RATE and SERIAL OUT DEVICE.
 - GARMIN 296
 - GARMIN 396
 - GARMIN 495 / 496
 - GARMIN 695 / 696
 - GARMIN AERA
2. Make sure NAVIGATION SOURCE DISPLAY NAME is set to (NOT SET).
3. Make sure SERIAL OUT DEVICE is set to NONE.
4. Set SERIAL IN FUNCTION to POS 1, 2, 3. If the Garmin GPS device is the only GPS
device, select POS 1. If the Garmin GPS device is being used as a backup GPS source
to an SV-GPS-250/2020 or another GPS device, select POS 2 or 3 as appropriate.

3.5 Emergency Location Transmitter (ELT) Devices

SkyView can provide a GPS data stream to ELTs that accept GPS data in NMEA format.

To connect the ELT:

1. Connect ELT's RX input to a SkyView serial TX.
2. Ensure a shared ground between the SkyView display unit and the ELT.



If there is more than one display unit in SkyView system, repeat same connections to all display units.

To configure SkyView:

- Enter SETUP MENU > SYSTEM SETUP > SERIAL PORT SETUP > SERIAL PORT '#'
SETUP and select:
 - SERIAL IN DEVICE: NONE (does not affect ELT)
 - SERIAL IN/OUT BAUD RATE: (enter numeric value to match ELT speed)
 - SERIAL OUT DEVICE: NMEA OUT (BASIC).

3.6 Vertical Power VP-X

SkyView can interface with the Vertical Power VP-X system to provide robust monitoring and control of the aircraft's electrical system via SkyView. To use this feature, a VP-X License (SV-VPX-290) must be purchased.



For full VP-X functionality, an EMS module is required because VP-X information is displayed in the EMS window. Therefore, if the SkyView system does not include an SV-EMS-220 or SV-EMS-221, VP-X information cannot be displayed.

3.6.1 VP-X System Installation and Configuration

Refer to VP-X manufacturer's documentation (<http://verticalpower.com/documents/>) for information about the mechanical and electrical installation and configuration of the VP-X unit, as well information about the connections between the VP-X and the aircraft's electrical system circuits.

When planning a SkyView system with VP-X, it should be noted that to monitor the status and reset a VP-X circuit at least one SkyView display unit must be powered up for VP-X status to be displayed. It can be problematic to troubleshoot a VP-X issue if power to all SkyView display units is controlled by the VP-X.



To ensure that you can monitor the status and reset circuits of the VP-X, it's recommended to power at least one SkyView display unit from a power source other than the VP-X unit.

Alternatively, you can equip SkyView display units with SV-BAT-320 backup batteries. With an SV-BAT-320, a SkyView display unit can be powered up on backup battery power by pushing and holding Button 1. As soon as aircraft power is received by the SkyView display unit, SkyView will switch to aircraft power.



SkyView modules such as the SV-ADAHRS-200/201, SV-EMS-220/221, and SV-ARINC-429 receive power via the SkyView Network. Their power supplies are managed entirely by the SkyView display units and cannot be separately monitored by the VP-X system. However, SkyView components that have power supplied by aircraft power, such as the AP servos, SV-ADSB-470/472, SV-COM-760, -T25/T8, -425, SV-XPNDR-261/262, and Heated AOA/Pitot Probe can have their power monitored by the VP-X by routing the power connections for those components via the VP-X.



The SV-HARNESS-D37 harness for each SkyView display unit contains a twisted pair of red power wires and a twisted pair of black ground wires. The pair of wires are a single power input and a single ground connection and must be connected to a single VP-X input when using the VP-X to provide power to SkyView display units. The dual wiring scheme is needed to provide adequate power to the SkyView display units given the electrical constraints of the wires and DSUB connectors / pins used. These wires should not be sent to separate power channels or be considered redundant power sources.

3.6.2 Serial Port Connection

All communication between the VP-X system and SkyView is accomplished via a single, bidirectional RS-232 serial connection.

Table 82 shows the connections for each of a SkyView display units' nominally available serial ports (serial port 5 is reserved for connection to the SV-GPS-250/2020 module). Only ONE of the following serial ports will be used.

Table 4: SkyView / VP-X Serial Port Connections

SERIAL PORT	D37 HARNESS	VP-X
1	Pin 3 (RX) Brown/Violet	J1 Pin 20 (TX)
	Pin 4 (TX) Brown/Orange	J1 Pin 22 (RX)
2	Pin 5 (RX) Yellow/Violet	J1 Pin 20 (TX)
	Pin 6 (TX) Yellow/Orange	J1 Pin 22 (RX)
3	Pin 7 (RX) Green/Violet	J1 Pin 20 (TX)
	Pin 8 (TX) Green/Orange	J1 Pin 22 (RX)
4	Pin 9 (RX) Blue/Violet	J1 Pin 20 (TX)
	Pin 10 (TX) Blue/Orange	J1 Pin 22 (RX)

Record the SkyView display serial port to which you connected the VP-X – you will need that information to configure SkyView to communicate with the VP-X.

Note that if you have more than one SkyView display unit, the same connections must be made to all SkyView display units.

To ensure reliable serial communications between the VP-X and SkyView, connect a wire from VP-X Connector J1, Pin 21 to the same grounding point used by SkyView display unit's 37-pin connector, Pin 21 and Pin 22 (twisted Black wires).

3.6.3 License Information

VP-X features are enabled on your SkyView system by purchasing and installing an VP-X License (SV-VPX-290). Only one VP-X License is needed in a SkyView system, no matter how many display units are attached. That license is applied to only one display, but that display stores the license information for the entire system. In normal use, license information is shared with all displays connected via SkyView Network to allow the VP-X features to be operated on any display in the system.

Checking License Status

To check whether a SkyView system is licensed to use the VP-X Software features, go to SETUP MENU > LOCAL DISPLAY SETUP > LICENSE, and look at the status of the Vertical Power line.

Possible license statuses include:

- **LICENSED (THIS DISPLAY):** A VP-X License has been installed, enabling the use of VP-X features. This SkyView display unit stores the license information and allows other displays in the aircraft to access the VP-X features.
- **LICENSED - CONNECTED DISPLAY ONLINE:** The SkyView system is licensed to use the VP-X features. This SkyView display is currently connected to a licensed display.
- **LICENSED DISPLAY OFFLINE - XX HOURS REMAIN:** The SkyView system is licensed to use the VP-X features. However, the SkyView display unit that stores the license information is not currently connected. When this happens, the VP-X features will continue to be accessible for 30 flight hours beyond when the SkyView display unit that stores the license information was last connected to the SkyView system. Once the SkyView display unit that stores the license information is reconnected, this timer is cleared.
- **NO LICENSE:** None of the SkyView display units in the system have a VPX License installed.

3.6.4 Purchasing and Installing a VP-X License (SV-VPX-290)



Display and control of VP-X is not supported in SkyView SE. If intending to install and use SkyView SE, do not purchase and install a VP-X or an VPX License.

An VPX License can be purchased and applied to your system in one of two ways:

1. Call Dynon directly at 425-402-0433 (have a SkyView display unit model and serial number ready). Purchasers will receive a six-digit license code that is entered in SETUP MENU > LOCAL DISPLAY SETUP > LICENSE > LICENSE CODE. The license is for the aircraft that will have the VP-X features. If there is more than one display unit in the aircraft, choose one unit where license is entered and provide information for only that display. Once any display is licensed, all connected displays in the aircraft can use the VP-X features.

2. A VPX License certificate may be purchased from Dynon or any authorized Dynon dealer. To redeem a certificate, simply follow the instructions on the certificate itself. Redeem the certificate by visiting dynon.com/redeem or call Dynon Avionics directly at 425-402-0433 (have the SkyView display unit model and serial number ready). See above for entering the license code.



Display unit serial numbers are found on the case sticker, or in SETUP MENU > LOCAL DISPLAY SETUP > DISPLAY HARDWARE INFORMATION.

3.6.5 SkyView / VP-X Configuration Settings

SkyView Serial Port Setup



Before the VP-X SETUP menu can be accessed in a SkyView display unit, the system must be licensed to use the VP-X features. See the section above for how to obtain and install an VP-X License.

To configure a SkyView display unit's serial port to work with VP-X:

1. Navigate to SETUP MENU > SYSTEM SETUP > SERIAL PORT SETUP.
2. From SERIAL PORT '#' SETUP, select VP-X, and then press ACCEPT.
3. Exit SETUP. Repeat on any other displays on your SkyView system.

VP-X Settings

Most VP-X setup – such as setting circuit breaker limits – is NOT done via SkyView, but instead via a Windows-based application called VP-X Configurator. See your VP-X documentation for full VP-X installation and setup information.



Although VP-X trim and flaps calibrations are not used by SkyView, leaving any of the VP-X trim or flaps end points or neutral positions to “0” in the VP-X Configuration program will cause SkyView’s trim or flaps indications to not display properly. To avoid this, set all the trim and flaps end points and neutral points to “1” in the VP-X Configurator.

The VP-X settings in the SETUP MENU > VP-X SETUP menu mainly concern how information from the VP-X is displayed in SkyView:

- **MAIN BATTERY WARNINGS:** Sets the main battery voltage levels at which caution, and warning indications are provided visually on the VP-X page.
- **AUX BATTERY WARNINGS:** Sets the auxiliary battery voltage levels at which caution, and warning indications are provided visually on the VP-X page. If you do not have an auxiliary aircraft battery (note that this is NOT the SkyView SV-BAT-320) installed, this setting can be ignored.
- **SYSTEM AMPS:** Sets the current levels for the entire electrical system at which caution, and warning indications are provided visually on the VP-X page.

- ALTERNATOR AMPS: Sets the current levels for the alternator at which caution, and warning indications are provided visually on the VP-X page.
- BATTERY AMPS: Sets the discharge rate at which caution, and warning indications are provided visually on the VP-X page.
- SKYVIEW AMPS SHUNT LOCATION: Depending on your electrical layout, your SkyView shunt may be in one of a few places in your electrical system.
- AILERON TRIM POSITION / ELEVATOR TRIM POSITION / FLAP POSITION: Set to SKYVIEW EMS if your trim and/or flaps position signal input is routed to your SV-EMS-220/221 module, or to VP-X if it is connected to your VP-X system instead. If set to VP-X, the engine page trim and/or flaps widgets will be sourced from the VP-X position information. Note that even when using the VP-X as your trim and/or flaps position source, you do still need to perform the SkyView-based calibration routine for the trim information to display properly in SkyView. These calibrations can be found under SETUP MENU > HARDWARE CALIBRATION > EMS CALIBRATION. You do not need to perform that VP-X Configurator-based calibration. However, set all the points in the VP-X Configurator to “1”.
- To display a battery voltage widget that displays battery voltage connected to the VP-X, go to SETUP MENU > EMS SETUP > SCREEN LAYOUT EDITOR > (xx % PAGE) > SENSOR (button) > BATT VOLTS (VP-X) > ACCEPT (button) > STYLE (per your preference) > SIZE (per your preference) > SAVE (button).

3.6.6 Post Installation Checks

Complete the following before using the VP-X system:

- Follow all installation, configuration, and test procedures as instructed by the VP-X documentation.
- Ensure that your VP-X system is powered on and functioning normally.
- On a SkyView display unit that is displaying the Engine Page (enabled by toggling MENU > SCREEN > EMS PG), press to MENU > ENGINE > VP-X. The Engine page will automatically re-arrange itself to show VP-X information as seen in the image below. If the VP-X page is covered by a red “X”, the VP-X is either not communicating with SkyView, is not properly configured, or is inoperative.

4 Appendix 1: NMEA OUT Data Formats

NMEA output data consists of industry standard NMEA 0183 Version v4.00 sentences. A reference for Version 4.00 of the standard can be found here:

www.nmea.org/content/nmea_standards/nmea_083_v_400.asp

4.1.1 NMEA OUT (BASIC)

NMEA OUT (BASIC) serial output data consists of GGA, GSA, GSV, RMC, and VTG sentences nominally output at a rate of 1 Hz. The rate is reduced if necessary, to transmit the entire set of data at the selected baud rate. This format outputs GPS data for position, speed, altitude, and heading.

For example, the following is one cycle of NMEA OUT (BASIC) serial output data:

```
$GPGGA,214921,3121.6199,N,00000.0000,E,1,04,1.90,3000.0,M,33.9,M,,0000*62
$GPGSA,A,3,01,02,03,04,00,00,00,00,00,00,00,00,1.00,1.90,1.90*07
$GPGSV,1,1,04,01,20,100,10,02,30,200,56,03,45,300,32,04,62,045,05*7A
$GPRMC,214921,A,3121.6199,N,00000.0000,E,82.07,1.00,300811,0.51,W,A*01
$GPVTG,1.00,T,0.51,M,82.07,N,151.99,K,A*1E
```

4.1.2 NMEA OUT (FULL)

NMEA OUT (FULL) data consists of all the NMEA OUT (BASIC) sentences followed by RMB, GLL, BWC, XTE, BOD, and APB sentences nominally output at a rate of 1 Hz. The rate is reduced if necessary to transmit the entire set of data at the selected baud rate. This format outputs navigation information derived by SkyView and is like the output that many handheld portable aviation GPS navigators generate.

For example, the following is one cycle of NMEA OUT (FULL) serial output data:

```
$GPGGA,221755,3157.4430,N,00000.0000,E,1,04,1.30,3000.0,M,33.9,M,,0000*66
$GPGSA,A,3,01,02,03,04,00,00,00,00,00,00,00,00,1.00,1.30,1.40*00
$GPGSV,1,1,04,01,20,100,10,02,30,200,56,03,45,300,32,04,62,045,05*7A
$GPRMC,221755,A,3157.4430,N,00000.0000,E,82.07,1.00,300811,0.49,W,A*06
$GPVTG,1.00,T,0.49,M,82.07,N,151.99,K,A*17
$GPRMB,A,9.99,L,FHAW,TUPJ,1826.7333,N,06432.4998,W,999.9,273.6,005.1,V,A*41
$GPGLL,3157.4430,N,00000.0000,E,221755,A,A*42
$GPBWC,221755,1826.7333,N,06432.4998,W,273.6,T,274.1,M,999.9,N,TUPJ,A*67
$GPXTE,A,A,9.99,L,N,A*0A
$GPBOD,299.3,T,299.8,M,TUPJ,FHAW*4F
$GPAPB,A,A,9.99,L,N,V,V,299.8,M,TUPJ,274.1,M,274.1,M,A*4E
```